

Planning Series

Frame Relay Interface Specifications

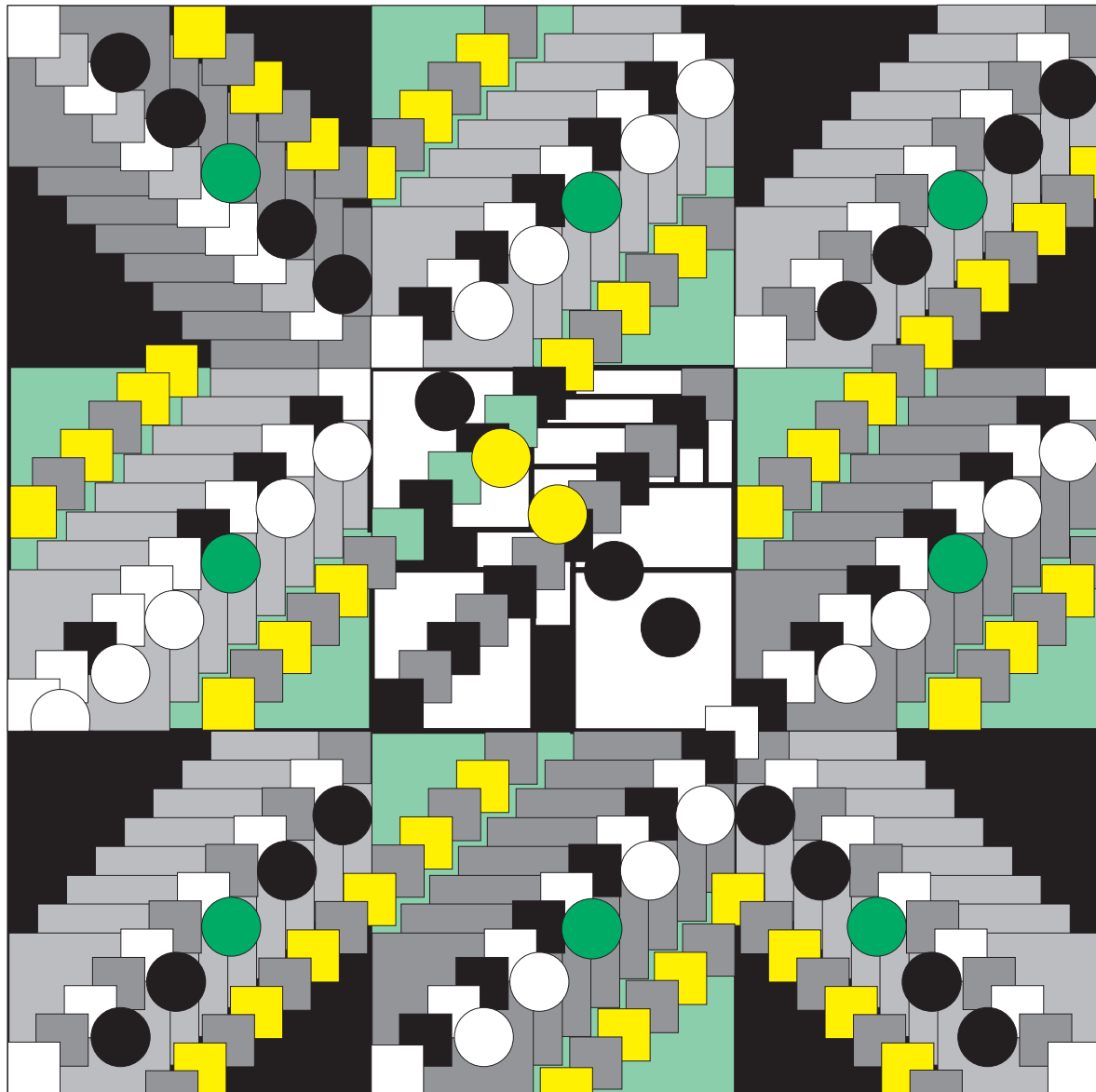

2220 Nways BroadBand Switch
Models 300, 500, and 501



Planning Series Frame Relay Interface Specifications

Note

Before using the information given in this document, be sure to read the general information and notices provided in the *2220 Nways BroadBand Switch Physical Lines Interface Specifications, External Cable References*, GA33-0379.

Sixth Edition (February 1999)

This edition applies to the following IBM licensed programs:

- Nways Switch Control Program Version 2 Release 2 (V2R2)
- Nways 2220 Switch Manager for AIX Version 1 replaces Nways Enterprise Manager Release 3.

The information contained in this document is subject to change from time to time. Any such changes will be reported in subsequent revisions.

Order publications through your IBM representative or the IBM branch office serving your locality. Publications are not stocked at the address given below.

A form for readers' comments appears at the back of this publication. If the form has been removed, address your comments to:

IBM France
Centre d'Etudes et Recherches
Service 0798 - BP 79
06610 La Gaude
France

- FAX: 33 4 93 24 77 97
- IBM Internal Use: LGERCF at IBMFR
- Internet: lgercf_fr@ibm.com

When you send information to IBM, you grant IBM a non-exclusive right to use or distribute the information in any way it believes appropriate without incurring any obligation to you.

© **Copyright International Business Machines Corporation 1995, 1999. All rights reserved.**

Note to U.S. Government Users — Documentation related to restricted rights — Use, duplication or disclosure is subject to restrictions set forth in GSA ADP Schedule Contract with IBM Corp.

Contents

Figures	vii
Tables	ix
About This Document	xi
Who Should Use This Document	xi
Purpose of This Document	xi
How This Document Is Organized	xi
Where To Find More Information	xi
What's New in This Book.	xi
Chapter 1. Nways Switch and Frame Relay	1
Access Services	1
Frame Handling Functions	2
Local Management Interface Functions	2
Bandwidth Modes	2
Physical Lines	3
Channels.	3
FR Logical Ports	4
FR Connections	4
Frame Relay over ISDN	4
Frame Relay / ATM Interworking	5
Chapter 2. Configuring Frame Relay Resources	7
Nways Switch Configuration Programs	7
Configuring FR Ports	7
Configuring FR Connections	8
Traffic Parameters	9
NBBS Traffic Parameters.	9
Frame Relay Traffic Parameters	9
QoS Options	10
Bandwidth Adaptation (ADJ).	10
Bandwidth Keeping (KEEP)	10
Non-Disruptive Path Switching (NDPS).	10
Low-Speed Trunk Line (LS)	10
High Priority (HPRI).	11
Non-Reserved (NR).	11
Using Predefined QoSs	11
QoS for FR Non-Real-Time Traffic	11
QoS for FR Real-Time Traffic	12
QoS for FR Non-Reserved Traffic.	13
Configuring Frame Relay over ISDN Connections.	13
FR over ISDN Port Parameters	13
FR over ISDN Connection Parameters.	14
Chapter 3. More Information on FR Options	17
Default QoS Options	17
Activating Connections.	17
Frame-Relay Frame Format.	17
Valid DLCI Ranges	19
Bandwidth Adaptation	19
Non-Disruptive Path Switching	19
Bandwidth Preemption.	20

At Connection Setup	20
After Link Failure	20
On Bandwidth Request	21
Bandwidth Management	21
Allocating Bandwidth	21
Leaky Bucket Policing	22
Traffic Descriptors	22
Bandwidth Modes	22
Fixed Bandwidth	23
Bandwidth Adaptation Without Limits	24
Bandwidth Adaptation With Limits.	25
Frame-Relay with CIR Defined.	27
Frame-Relay with CIR Null	29
Frame-Relay Real-Time	30
Frame-Relay Non-Reserved.	31
Selecting Bandwidth Mode	31
Local Management Interface (LMI)	32
User Network Interface (UNI)	33
Network Node Interface (NNI)	33
Information Elements (IEs)	33
LMI Procedures	36
Congestion Management	38
Policing Connections	38
Global Adapter Congestion	39
Severe Adapter Congestion	39
Chapter 4. ATM / Frame Relay Interworking	41
Overview.	41
Network Interworking	41
NIWF: Two Frame Relay Devices.	42
NIWF: Frame Relay and ATM Devices	43
NIWF Example	44
Service Interworking	45
SIWF Example 1	46
SIWF Example 2	47
Interworking Specifications	48
Appendix. Notices	49
Notices	49
European Union (EU) Statement	49
Year 2000 Statement	49
Electronic Emission Notices.	49
Trademarks and Service Marks	51
Bibliography	53
Nways Switch Publications	53
Nways 2220 Switch Manager Publications	53
TME 10 NetView for AIX Version 5 Publications	53
TMN 2.2 Publications	53
TME 10 Software Distribution Publications	53
OSI System Management Standards for CMIP	53
OSI Management Framework and Overview.	53
CMIP/CMIS.	53
Systems-Management Functions	53
Management Information Model	54
World Wide Web	54

Glossary	55
Index	65
Readers' Comments — We'd Like to Hear from You.	67

Figures

1. Frame Relay Traffic Supported by NBBS Network	1
2. Frame Relay Over ISDN	5
3. Bandwidth Adaptation	26
4. Status Enquiry from the User Side	34
5. LIV Status Answer from Network Side	34
6. Full Status Answer from Network Side	35
7. Asynchronous Status Notification from Network Side	36
8. LMI Procedure and Timing	37
9. Network Interworking with Two Frame Relay Devices	42
10. Network Interworking with a Frame Relay Device and an ATM Device	43
11. Network Interworking Function Example	44
12. Service Interworking.	45
13. SIWF Example 1	46
14. SIWF Example 2	47

Tables

1.	Physical Lines Supported by Frame Relay	3
2.	LMI Parameters	8
3.	Predefined QoS for FR Non-Real-Time Traffic	12
4.	Predefined QoS for Frame Relay Real-Time Traffic	12
5.	Predefined QoS for Frame Relay Non-Reserved Traffic	13
6.	FR QoS: System Defaults.	17
7.	Valid DLCI Ranges	19
8.	Frame Relay Traffic Descriptors	22
9.	LMI Information Elements.	33

About This Document

Who Should Use This Document

Use this document if you are responsible for:

- Planning the installation of a network using IBM 2220 Nways BroadBand Switches (Nways Switches).
- Installing and configuring the network.

Purpose of This Document

This document describes:

- Functions provided by IBM Networking BroadBand Services (NBBS) architecture on frame-relay interfaces of Nways Switches.
- Special features for bandwidth utilization, optimization, and automatic rerouting of connections.

How This Document Is Organized

The document is organized as follows:

- “Chapter 1. Nways Switch and Frame Relay” on page 1 gives an introduction to the Frame-Relay access services provided by the Nways Switch.
- “Chapter 2. Configuring Frame Relay Resources” on page 7 provides recommendations for configuring Frame-Relay resources.
- “Chapter 3. More Information on FR Options” on page 17 describes certain Frame-Relay options.
- “Chapter 4. ATM / Frame Relay Interworking” on page 41 describes interworking between Frame-Relay and ATM networks.
- A Glossary is provided at the end.

Where To Find More Information

This document is a supplement to the *2220 Nways BroadBand Switch Planning Guide*, GA33-0293. For a complete list of customer information manuals, refer to “Bibliography” on page 53.

What’s New in This Book

The following functions are new or have changed in the Nways Switch Control Program since the last edition of this book:

- Interworking between ATM and Frame Relay networks is now supported.

Chapter 1. Nways Switch and Frame Relay

This document describes how the IBM 2220 Nways BroadBand Switch (*Nways Switch*) supports the frame-relay protocol.

Frame relay (FR) is a connection-oriented protocol to transport data frames over a fast packet-network with guaranteed end-to-end delay.

The Nways Switch supports non-real-time, real-time, and non-reserved frame relay traffic over permanent virtual circuits (PVCs). Devices that do not support the frame relay protocol can use the HDLC service to connect to a Networking BroadBand Services (NBBS) network.

Figure 1 shows the various types of frame-relay traffic supported by Nways Switches communicating over an 2220 network.

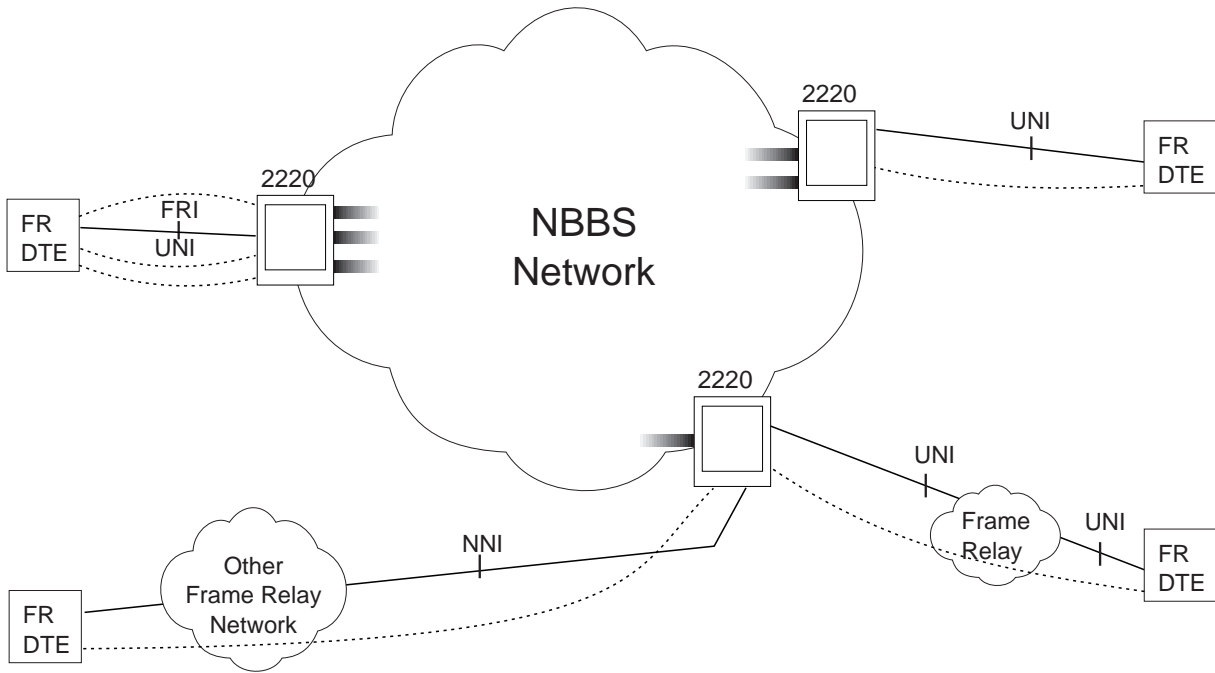

Legend:

- DTE** Data terminal equipment
- FRI** Frame-relay interface
- NNI** Network node interface
- UNI** User network interface

Figure 1. Frame Relay Traffic Supported by NBBS Network

Access Services

The Nways Switch provides the following frame-relay access services:

- Permanent virtual circuits are supported through user network interface (UNI) and network node interface (NNI).

- ANSI Standards T1.607/617/618 and ITU-T Recommendations I.122 and Q.922 Core Support are supported.
- Local management interface (LMI) DTEs and non-LMI DTEs are supported (for details, see “Local Management Interface (LMI)” on page 32). The Nways Switch complies with ANSI T1.617 Annex D and ITU-T Q.933 Annex A.
- Frame-relay logical ports are configured as frame-relay frame handler (FRFH) and frame-relay terminal equipment (FRTE).
- Data link control identifiers (DLCIs) are handled and DLCI swapping is performed.
- To save bandwidth, X'7E' flags and stuffed zero-bits are removed.

Frame Handling Functions

The Nways Switch provides the following frame handling services:

- Full duplex transfer of frames on permanent virtual circuits. Frames are received in the same order as they are transmitted. There is no acknowledgment to user of frames transferred across the network.
- Frame delimitation, alignment, and code transparency provided by insertion of flags and zero-bits (for details, see “Frame-Relay Frame Format” on page 17).
- Frame multiplexing and demultiplexing using address field.
- Transparent transport of user data contents (information fields) for each frame. Only the frame address and FCS fields may be modified.
- Transport of variable-length frames (from 5 to 8192 bytes). Each frame is checked for correct length.
- Detection of errors in transmission, format, and operation.
- User notification of congestion.

All frames with an error are discarded without notification to the frame-relay DTE.

Local Management Interface Functions

The Nways Switch supports the following functions through the local management interface (LMI):

- Optional asynchronous status message in both directions
- Optional delete in asynchronous status
- Remote signaling of permanent virtual circuit (PVC) activity (with end-to-end PVC status management in the network).

The following functions are not supported:

- NCP echo cancellation
- Automatic interface sensing.

Bandwidth Modes

The Nways Switch supports frame relay in the following bandwidth modes:

- Fixed bandwidth (non-real-time)
- Bandwidth adaptation without limits (non-real-time)
- Bandwidth adaptation with limits (non-real-time)
- Frame-relay with committed information rate (CIR) defined (non-real-time)

- Frame-relay with CIR null (non-real-time)
- Frame-relay real-time
- Frame-relay non-reserved.

For more information, see “Bandwidth Modes” on page 22.

Physical Lines

Table 1 lists the types of lines supported by frame relay and the associated line interface couplers (LICs):

Table 1. Physical Lines Supported by Frame Relay

Line Type	Line Interface Coupler
T1 or J1	514 (four interfaces)
	544 (eight interfaces)
E1	515 (four 75-Ohm interfaces)
	516 (four 120-Ohm interfaces)
	567 (four ISDN 120-Ohm interfaces)
	545 (eight 75-Ohm interfaces)
	546 (eight 120-Ohm interfaces)
E2, J2, E3	523 (four interfaces)
HSSI	530 (one interface)
T3	513 (one interface)
V.24, V.35, X.21	511 (sixty interfaces)
V.35, V.36, X.21	522 (four interfaces)

Each of the frame-relay lines is a *port line*. It attaches a frame-relay device to an Nways Switch and is a port to the 2220 network. Frame-relay port lines transport only frame-relay traffic.

For cabling information, see the *2220 Nways BroadBand Switch Physical Lines Interface Specifications, External Cable References, GA33-0379*.

Channels

On E1, T1, or J1 line interfaces, you may define each 64 kbps slot as a dedicated frame-relay link with its own range of DLCI. For instance, using a LIC515 with four E1 interfaces, you may define up to 124 (31x4) frame-relay links.

Note: *kbps* means 1000 bits per second.

It is also possible to define a frame-relay link based on several 64 kbps slots (for example, 256 kbps). This is called *bonding*. The slots can be contiguous or not.

The maximum number of connections is defined at adapter level, not at port level. Despite the number of ports defined on an adapter, the maximum number of connections that an adapter can handle at the same time remains the same. In

frame-relay, there may be several connections on a logical port. Each connection has its own virtual circuit number (VCN) and is associated with a data link circuit identifier (DLCI).

FR Logical Ports

Frame-relay logical ports (layer 2 of the OSI reference model) are called *FR ports*. They are generated by the Nways Switch Control Program to provide frame-relay access services to physical frame-relay port lines. An FR port sets up and maintains predefined FR connections.

FR Connections

In an 2220 network, frame-relay connections are predefined between to FR devices attached to the network. FR connections are point-to-point and unidirectional. They operate in real-time and non-real-time over permanent virtual circuits (PVCs) and are always created in pairs:

- One *FR potential connection* on the forward direction
- One *FR virtual connection* on the return direction.

Frame Relay over ISDN

The Frame Relay over ISDN function allows frame relay Data Terminal Equipment (DTE) to access 2220 frame relay ports through dial-up ISDN connections in addition to accessing the 2220 network through direct attachments and leased lines. Frame Relay over ISDN allows you to:

- Reduce costs when remotely accessing the 2220 frame relay network for a few hours each day with limited traffic from several business locations. End-to-end digital connections at 64 Kbps with a low error rate are provided at approximately the cost of a telephone call.
- Reduce costs in backing up leased lines between an Nways Switch and frame relay DTE over ISDN. You pay for the backup ISDN connection only for the time of the leased line failure.
- Handle frame relay overflows on leased lines by dialing up the Nways Switch over ISDN to set up additional frame relay PVCs. The establishment and release of the switched ISDN connection is controlled by the frame relay DTE.

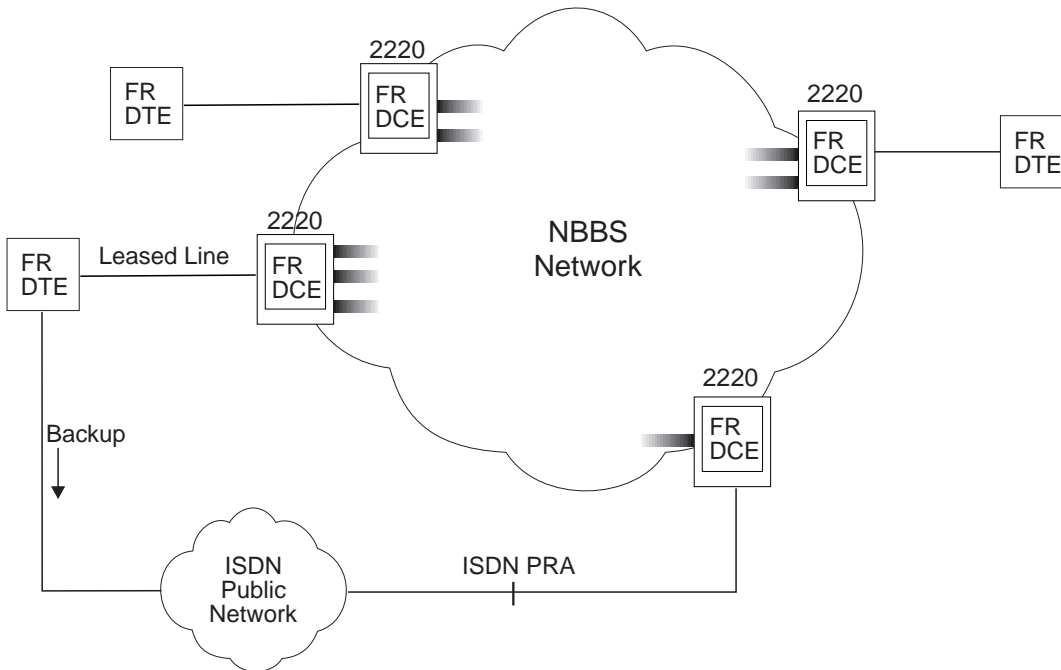

Figure 2. Frame Relay Over ISDN

The following interfaces are supported for Frame Relay over ISDN:

- Euro-ISDN Primary Rate Access (PRA) E1 compliant with ETS 300-1 on 4-port E1 (LICs 515, 516, and 567) and 8-port E1 (LICs 545 and 546). (LIC 567 is required to access public networks that require Euro-ISDN homologation.)
- Japan NTT Primary Rate Access (PRA) J1 compliant with the INS-Net 1500 specification with 4-port J1 (LIC 514) or 8-port J1 (LIC 544).

Frame Relay / ATM Interworking

The IBM 2220 supports interworking between Frame Relay and ATM networks with two functions:

Network Interworking Function (NIWF)

Two Frame Relay devices communicating over an ATM network.

Service Interworking Function (SIWF)

A Frame Relay device communicating with an ATM device, where neither device knows that the other device is connected using a different protocol.

These interworking functions are described in “Chapter 4. ATM / Frame Relay Interworking” on page 41.

Chapter 2. Configuring Frame Relay Resources

This chapter provides recommendations for configuring frame-relay resources (logical ports and connections) and traffic options.

Nways Switch Configuration Programs

Frame-relay resources (line attachments, logical ports, and connections) are configured using either:

- Nways Switch Configuration Tool Version 2 (NCT2) from a dedicated configuration station running under OS/2 or AIX
- Nways Switch Manager (component of the Nways Enterprise Manager) from a network management station.

For information on configuration parameters, see the online help. For guidelines on how to configure HDLC resources, refer to the *Nways Switch Configuration Overview* supplied with the NCT2.

Configuring FR Ports

In an 2220 network, you configure an FR port for each frame-relay physical line. Using the 64 kbps time slots, you can create channels on port lines working in time division multiplexing (E1, T1, or J1). You can create a channel for each time slot or group of time slots, and you configure one FR port on each channel.

The following physical interfaces support multiple FR ports:

- E1 line with LICs 515, 516, 545, 546, and 567
- T1 and J1 lines with LICs 514 and 544.

Before creating frame-relay connections, you must create FR ports on both Nways Switches at the end-points of the connection. On one end, the port serves as *connection initiator*. On the other end, the port serves as *connection completer*. A connection is always activated from the initiator logical port. Generally FR ports are configured as both connection initiator and connection completer.

Some of the FR port parameters to configure are as follows:

- FR port name
- Attached resource identification
- Line attachment location (rack, slot, position, and channel, if any)
- Connection initiator, completer, or both
- Administrative state (locked or unlocked)
- Maximum bandwidth available (default value: line speed).

You can also define the following frame-relay options:

- Interval of authorized data link connection identifier (DLCI) values. Default values are from 16 to 991.
- Number of configured DLCIs (updated by the configuration program)
- Maximum number of permanent virtual circuits (PVCs). Default value: 400.
- Local management interface (LMI) type: none, ANSI standard T1.617-D, or ITU-T Q.933-A.

- LMI mode: user, network, user and network.

You can also configure LMI parameters, such as:

- N391 full status polling counter
- N392 error threshold
- N393 monitored events count
- T391 link integrity verification polling timer
- T392 polling verification timer.

Table 2. LMI Parameters

LMI Parameter	Description	Range (Default)	Side
N391	Full status of PVC polling counter. Number of polling cycles between two full statuses.	1 to 255 (6)	User side
N392	Error threshold (number of errors).	1 to 10 (3)	User and network sides
N393	Monitored events count. An LMI failure is reported when N392 errors have been detected on N393 events.	1 to 10 (4)	
T391	LIV polling timer: time (in seconds) between two enquiries.	5 to 30 (10)	User side
T392	Polling verification timer. Maximum time (in seconds) between a status and the next enquiry.	5 to 30 (15)	Network side

For more information about the LMI parameters, see “Local Management Interface (LMI)” on page 32.

Configuring FR Connections

You configure FR potential connections for each FR port defined as connection initiator. On the remote FR port, you configure virtual connections which are the return paths of the potential connections. FR ports on each end of the connection are defined as both connection initiator and completer.

It is possible to define several FR connections with different data link connection identifiers (DLCIs) on the same FR port. The connections can be activated at the same time.

Associated potential and virtual connections have the **same virtual circuit number**. To be displayed together using the Nways 2220 Switch Manager, they must have the **same name**.

Some of the frame-relay connection parameters to configure are as follows:

- Virtual circuit number (VCN) computed by the configuration program
- Connection name
- For potential connection: identification of initiator resource (Nways Switch, port, resource, and DLCI)
- For virtual connection: identification of completer resource (Nways Switch, port, resource, and DLCI)

- Traffic definition mode (for details, see “NBBS Traffic Parameters” or “Frame Relay Traffic Parameters”)
- Quality of service for both directions (for details, see “QoS Options” on page 10)
- Connection activation mode: permanent or none (for details, see “Activating Connections” on page 17)
- Accounting selection and bandwidth sensitivity over which accounting information is recorded.

Nways Switch configuration programs allow you to set DLCI ranges to create a series of potential and virtual connections.

Traffic Parameters

When configuring frame-relay potential connections, you define the traffic characteristics using either NBBS or frame-relay parameters.

NBBS Traffic Parameters

Peak bit rate

Speed (in kbps) of the line that receives traffic from the user. This is the maximum throughput that the line can send to the access node. This value must be less than or equal to the link capacity. The default value is the link capacity.

Mean bit rate

Average traffic (in kbps) received from the user. This value must be less than or equal to the peak bit rate. Default value: 0.1 kbps.

Mean burst length

Maximum duration (in seconds) of a burst of traffic received from the user at peak rate. Range: 0 to 10 seconds. Default value: 0.01 s.

Adaptation limits

This option is configured when you select the bandwidth adaptation option (ADJ). Default values: 0.1 kbps for minimum limit and the link capacity for maximum limit for sending and receiving data.

If you change the adaptation limits for a connection, follow these rules:

- The minimum limit must be equal to or greater than its default value.
- The maximum limit must be equal to or lower than the peak bit rate.
- The mean bit rate must be within the adaptation limits.

Frame Relay Traffic Parameters

Access rate (AR)

Speed (in kbps) of the line that receives traffic from the user. This is the maximum throughput that the line can send to the access node. This parameter is the same as the NBBS peak bit rate and must be less than or equal to the link capacity. The default value is the link capacity.

Committed information rate (CIR)

Average traffic (in kbps) received from the user. This parameter is the same as the NBBS mean bit rate and must be less than or equal to the access rate. There is no default value.

Burst committed (Bc)

Maximum length (in bits) of a burst of traffic received from the user at peak rate. Range: 0 to 50 000 000. There is no default value. Traffic below the Bc value has a very high probability of being transported.

Burst in excess (Be)

Maximum length (in bits) of a burst of traffic in excess. Traffic above Bc+Be is not guaranteed and may be discarded.

QoS Options

Depending on the type of traffic and the way you want the connection to be managed by the 2220 network, you assign a quality of service (QoS) to each FR potential connection. The following QoS options define the possible characteristics of a connection:

- Bandwidth adaptation
- Bandwidth keeping
- Non-disruptive path switching
- Low-speed trunk line
- High priority
- Non-reserved.

Bandwidth Adaptation (ADJ)

Bandwidth adaptation (ADJ) allows Nways Switches along a connection to modify the required bandwidth depending on the current traffic and available resources. Bandwidth is adjusted within the limits configured for the connection (for details, see “Bandwidth Adaptation” on page 19). If there is not enough bandwidth, the connection is interrupted unless you selected the non-disruptive path switching (NDPS) option.

Bandwidth Keeping (KEEP)

When you select *bandwidth keeping* (KEEP) in addition to bandwidth adaptation (ADJ), if a bandwidth increase is requested and there is not enough bandwidth, the current bandwidth is kept and the connection is not terminated. Bandwidth keeping has no effect on connection activation and connection recovery after a link failure.

Non-Disruptive Path Switching (NDPS)

Non-disruptive path switching (NDPS) ensures that when a link fails in the 2220 network or if the current path is lacking resources, connections with the NDPS option are rerouted to another available path or to a parallel 2220 trunk. The Nways Switch that is the connection initiator reroutes the connections. When the NDPS option is not selected, connections are terminated and re-established by the Retry mechanism only when the path is available. For more information, see “Non-Disruptive Path Switching” on page 19.

Low-Speed Trunk Line (LS)

In data transmission, the low-speed trunk lines may have a wide end-to-end transfer delay because the transmitted data is buffered by the Nways Switch adapters along

the path. For data traffic that does not need real-time transmission, these transfer delays have a minor impact on the data applications that are connected through the 2220 network.

When you select *low-speed* (LS) trunk line, although the allowed end-to-end delay is much greater, finding suitable paths is much easier. If low-speed lines are used and LS is not selected, connections can be rejected because the maximum end-to-end delay calculated on the path is wider than the delay required.

High Priority (HPRI)

If a path fails, it is possible that there is no longer sufficient bandwidth to support all existing connections. If you select *high priority* (HPRI), the bandwidth preemption function ensures that the connection is given first access to bandwidth. The other connections get only the remaining bandwidth.

Bandwidth preemption is applied when one of the following events occurs:

- Connections are activated.
- A link fails.
- Bandwidth increase is requested.
- Connections with the NDPS option are rerouted.

For more information, see “Bandwidth Preemption” on page 20.

Non-Reserved (NR)

Non-reserved (NR) is a logical queue used for applications that require only best-effort delivery and do not require delay and bandwidth guarantees. Non-reserved is also used for internal 2220 network control flow.

Non-reserved traffic is used to optimize trunk usage by filling up lines when reserved traffic does not use all of its reserved bandwidth. 2220 network connections may be defined as non-reserved for frame relay access services.

Using Predefined QoSs

The Nways Switch configuration programs provide predefined QoSs which you can assign to FR connections in relation with their types of traffic. You select a predefined QoS by clicking in a list. Following are the FR traffic types:

- Non-real-time
- Real-time
- Non-reserved.

QoS for FR Non-Real-Time Traffic

Table 3 on page 12 shows the predefined QoS options for frame-relay non-real-time traffic. Their names begin with QOSFRHDL. For more information, see “Bandwidth Modes” on page 22.

Table 3. Predefined QoS for FR Non-Real-Time Traffic

Predefined QoS	Bandwidth Adaptation (ADJ)	Bandwidth Keeping (KEEP)	Non-Disruptive Path Switching (NDPS)	Low Speed Trunk Lines (LS)	High Priority (HPRI)
QOSFRHDLCL					
QOSFRHDLCADJ	X				
QOSFRHDLCLNDPS			X		
QOSFRHDLCADJNDPS	X		X		
QOSFRHDLCADJKEEP	X	X			
QOSFRHDLCADJKEEPNDPS	X	X	X		
QOSFRHDLCLLS				X	
QOSFRHDLCADJLS	X			X	
QOSFRHDLCLNDPSLS			X	X	
QOSFRHDLCADJNDPSLS	X		X	X	
QOSFRHDLCADJKEEPLS	X	X		X	
QOSFRHDLCADJKEEPNDPSLS	X	X	X	X	
QOSFRHDLCLHPRI					X
QOSFRHDLCADJHPRI	X				X
QOSFRHDLCLNDPSHPRI			X		X
QOSFRHDLCADJNDPSHPRI	X		X		X
QOSFRHDLCADJKEEPHPRI	X	X			X
QOSFRHDLCADJKEEPNDPSHPRI	X	X	X		X
QOSFRHDLCLLSHPRI				X	X
QOSFRHDLCADJLSHPRI	X			X	X
QOSFRHDLCLNDPSLSHPRI			X	X	X
QOSFRHDLCADJNDPSLSHPRI	X		X	X	X
QOSFRHDLCADJKEEPLSHPRI	X	X		X	X
QOSFRHDLCADJKEEPNDPSLSHPRI	X	X	X	X	X

QoS for FR Real-Time Traffic

Table 4 shows the predefined QoS options for frame-relay real-time traffic. Although these QoSs apply to FR and frame-relay, they are taken from the CES QoS series and their names begin with QOSCESDATA. The QoSs for FR real-time traffic provide a real-time class 2 (RT2) connection. For more information, see “Frame-Relay Real-Time” on page 30.

Table 4. Predefined QoS for Frame Relay Real-Time Traffic

Predefined QoS	Real Time Class 2 (RT2)	Non-Disruptive Path Switching (NDPS)	High Priority (HPRI)
QOSCESDATAHPRI	X		X
QOSCESDATANDPSHPRI	X	X	X

QoS for FR Non-Reserved Traffic

Table 5 shows the predefined QoS options for frame-relay non-reserved traffic. Their names begin with QOSFRHDLNCR. For more information, see “Frame-Relay Non-Reserved” on page 31.

Table 5. Predefined QoS for Frame Relay Non-Reserved Traffic

Predefined QoS	Non Reserved (NR)	Non-Disruptive Path Switching (NDPS)	High Priority (HPRI)
QOSFRHDLNCR	X		
QOSFRHDLNCRNDPS	X	X	
QOSFRHDLNCRHPRI	X		X
QOSFRHDLNCRNDPSHPRI	X	X	X

Configuring Frame Relay over ISDN Connections

Frame Relay over ISDN connections allow Frame Relay Data Terminal Equipment (DTE) to access 2220 Frame Relay ports through a dial-up ISDN connection. To configure a 2220 Frame Relay over ISDN connection for frame relay DTE, you use the Nways Switch Configuration Tool Version 2 (NCT2) to:

1. Configure the FR over ISDN port group.
2. Configure the FR over ISDN port on the connection initiator.
3. Configure the FR over ISDN connections.

You must also configure the ISDN network interface (Euro-ISDN or Japan ISDN) for Frame Relay remote access and define the appropriate hardware resources (LIC, LSA3 adapter, E1 or J1 line).

For more detailed information, refer to the *IBM 2220 Nways Broadband Switch Configuration Guide* (GA33-0474).

FR over ISDN Port Parameters

You must create a FR over ISDN port on the connection initiator. To create a FR over ISDN port, select the Nways Switch and specify the following parameters:

- Port type (Dial-in or Backup)
- Name definitions (node and port names)
- Primary name definitions (primary node and port names)
- Resource definitions (type of port and its identifier)
- FR over ISDN parameters (port group name and DTE calling number)
- Administrative state (status of the port when the Control Program is loaded: unlocked or locked)
- Maximum bandwidth available (bandwidth that is less than or equal to the line speed)

You must also configure the following frame-relay options:

- Interval of authorized data link connection identifier (DLCI) values. Default values: 16 to 991.
- Number of configured DLCIs (updated by the configuration program)
- Maximum number of permanent virtual circuits (PVCs). Default value: 400.
- Local management interface (LMI) type: none, ANSI standard T1.617-D, or ITU-T Q.933-A.
- LMI mode: user, network, user and network.

You can also configure the following LMI parameters:

- N391 full status polling counter
- N392 error threshold
- N393 monitored events count
- T391 link integrity verification polling timer
- T392 polling verification timer.

For detailed information on each parameter, see the online help provided in NCT2 and Nways 2220 Switch Manager.

FR over ISDN Connection Parameters

Each Frame Relay over ISDN connection consists of a *potential connection* and a *virtual connection*. You must configure a potential connection for each FR over ISDN port defined as connection initiator. On the remote FR over ISDN port, you must configure a virtual connection for the return path of the potential connection. The FR over ISDN ports are defined as both connection initiator and completer.

You can define several FR over ISDN connections with different data link connection identifiers (DLCIs) on the same FR over ISDN port. These connections can be activated at the same time.

Note: Associated potential and virtual connections have the **same virtual circuit number**. To be displayed together using Nways 2220 Switch Manager, they must have the **same name**.

Potential Connections

You must configure the following parameters for a Frame Relay potential connection:

- Connection name (up to 32 characters)
- Virtual circuit number: assigned by NCT2 and unique for the pair of potential and virtual connections
- Initiator identification (initiator Nways Switch, port, DLCI, and resource displayed by NCT2)
- Completer identification (completer Nways Switch, port, DLCI, and resource)
- Quality of Service: QoS assigned to the FR potential and virtual connections
- Traffic definition mode: NBBS (peak bit rate, mean bit rate, and mean burst length) or frame relay (AR, CIR, Bc, and Be)
- Connection activation mode: permanent or on reception of a start command from the network operator
- Administrative state: status of the connection when the Control Program is loaded (unlocked or locked)

- Accounting: connection accountable (if required) and bandwidth sensitivity over which accounting information is recorded

Use the “Apply then another” function in NCT2 to create another potential connection and automatically increment the VCN and DLCI numbers.

For more information on Frame Relay configuration options and QoSs, see “Traffic Parameters” on page 9 and “QoS Options” on page 10 or refer to the online help in NCT2 and Nways 2220 Switch Manager.

Virtual Connections

You must configure the following parameters for a Frame Relay virtual connection:

- Connection name used by the potential connection (up to 32 characters)
- Virtual circuit number: assigned by NCT2 if the virtual connection has been created automatically
- Initiator identification (initiator Nways Switch, port, DLCI, and resource)
- Completer identification (completer Nways Switch, port, DLCI, and resource displayed by NCT2)

As when configuring FR potential connections, you can use the “Apply then another” function in NCT2 to create another virtual connection and automatically increment the VCN and DLCI numbers.

Chapter 3. More Information on FR Options

Default QoS Options

Table 6 displays the default settings in the Nways Switch Control Program for certain QoS options used in FR traffic.

Table 6. FR QoS: System Defaults

QoS Option	Without bandwidth adaptation	With bandwidth adaptation
Bandwidth adaptation (ADJ)	No	Yes
Bandwidth keeping (KEEP)	Not applicable	Yes
Logical queues	Real-time class 2, non-real-time, or non-reserved	
End-to-end delay	200 ms to 10 s	2 ms to 10 s
Maximum number of hops	10	10

When a connection is established, the Path Selection function minimizes the number of hops and the trunk load to guarantee the required end-to-end delay.

Activating Connections

Activating a connection means starting its set up over the network. The required Nways Switch resources (adapter, line interface coupler, and line attachments) must be available, the line must be unlocked, and the remote equipment must be ready. Otherwise, the connection set up will fail.

In an 2220 network, the Nways Switch that is the connection initiator activates the connection in one of the following modes depending on the Permanent Mode option:

- When you select Permanent Mode, the connection is activated when the Nways Switch resources, the line, and the remote equipment are ready.
- When you *do not* select Permanent Mode, the connection is activated only when a network operator enters a Start Connection command from the Nways 2220 Switch Manager.

Frame-Relay Frame Format

A frame-relay frame has the following structure:

- Opening flag (1 byte) containing a 01111110 bit pattern
- Address field (2 bytes) with the following structure:

Address field extension bits (2 bits).

Address field extension is not supported but is defined as follows: the first bit of the first address byte is set to **0**, the first bit of the second address byte is set to **1**.

C/R bit (1 bit)

The C/R bit is user-application dependent and is passed transparently to the remote end of the connection.

FECN or BECN (2 bits)

The 2220 network transparently carries the forward and backward explicit congestion notification (FECN and BECN) bits in incoming frames when they are set to 1. The 2220 network never resets them. If either bit in incoming frames is not set to 1, the 2220 network may use them, depending on its congestion or policing criteria.

The 2220 network sets:

- FECN bit to 1 to inform the receiving DTE that the frames it receives have encountered congested resources.
- BECN bit to 1 to inform the sending DTE that the frames it sends may encounter congested resources.

Network discard eligibility (DE) indicator (1 bit)

The DE bit in the incoming frames is transparently carried by the 2220 network, which uses it for selective discard when congestion occurs (without modifying its value).

Data link control identifier (DLCI) field (10 bits)

The DLCI field is used to identify the permanent virtual circuits (PVCs) multiplexed in each access channel. A total of 1000 PVCs (and DLCIs) can be active at the same time on the different physical interfaces of a port adapter.

The actual number of PVCs that can be active at the same time depends on the adapter type. The number is:

- 130 PVCs for a low-speed adapter type 1 (LSA1)
- 400 PVCs for a low-speed adapter type 2 (LSA2)
- 1000 PVCs for a low-speed adapter type 3 (LSA3).

Table 7 on page 19 shows the valid ranges of DLCI allocation.

- Frame length (5 to 8192 bytes) including address, information, and CRC fields
- Information field (1 to 8188 bytes)
- Frame check sequence (FCS) (2 bytes)

The Nways Switch at the network entry point performs cycle redundancy checking (CRC) on incoming frames and discards frames with errors by using the abend sequence process. Frames are not checked when they leave the 2220 network.

- Closing flag (1 byte) containing a 01111110 bit pattern.

The network discards **invalid frames** without notifying the sending terminal. A frame is invalid if:

- It is not properly bounded by the opening and closing flags.
- It has an improper length (less than five bytes or more than 8192 bytes) between flags.
- It is not made of an integral number of bytes before the insertion or after the extraction of the zero-bits.
- It contains a frame-check sequence error.

Reception of seven or more contiguous 1-bits is interpreted as an **abend** and is ignored.

Idle periods between frames are filled by 01111110 bit patterns.

Valid DLCI Ranges

Table 7. Valid DLCI Ranges

DLCI Number	Function
0	Reserved for in-channel signaling (LMI)
1-15	Reserved
16-991	Available to the user for logical link identification
992-1007	Not available (layer 2 management of frame-mode service provider is not supported)
1008-1022	Reserved
1023	Not available (in-channel, layer 2 management is not supported)
Note: CLLM (consolidated link layer management) messages are not supported by the 2220 network.	

Bandwidth Adaptation

When you select the bandwidth adaptation option (ADJ), the required bandwidth is adjusted depending on the current traffic and available resources. The option takes into account peak hours and empty hours, and modifications on connection requirements, such as interactive file transfer.

Bandwidth adaptation is performed as follows:

1. The connection input traffic is regularly measured to see if there are changes to make in bandwidth requirements.
2. Changes in bandwidth requirements are confirmed over a certain period of time (several seconds).
3. A request is sent over the network to increase or decrease bandwidth. In case of bandwidth increase, the network answer must be received before changing policing parameters.

Bandwidth adaptation guarantees a QoS while providing flexibility in reservation. On the contrary, the non-reserved service takes advantage of idle periods on trunks, but does not guarantee a QoS. You use bandwidth adaptation to take into account long term variations in traffic rather than short-term bursts. For more information on selecting a QoS with bandwidth adaptation, see “Bandwidth Adaptation (ADJ)” on page 10.

Non-Disruptive Path Switching

Non-disruptive path switching (NDPS) is a function that restores a connection over another network path if the current trunk fails or if there is insufficient bandwidth when bandwidth adaptation (see “Bandwidth Adaptation”) is performed.

When a trunk fails or when bandwidth adaptation cannot be successfully performed, the connections with the NDPS attribute are rerouted on another trunk (when possible). The rerouting order depends on the connection priority: high priority (HPRI), real-time class 2 (RT2), non-real-time (NRT), and non-reserved (NR). At the same priority level, the connection with the widest bandwidth is rerouted first. If necessary, low-priority connections are preempted on the trunk used for rerouting (see “Bandwidth Preemption” on page 20).

When a trunk with a parallel trunk configuration fails, the bandwidth used by the connections of the parallel trunk is reduced to its initial value so that the parallel trunk can transport the connections of the failing trunk.

When many connections require NDPS at the same time, a large amount of traffic control is created in the 2220 network. This can result in long rerouting delays. (For more information on selecting a QoS with the NDPS option, see “Non-Disruptive Path Switching (NDPS)” on page 10.)

Bandwidth Preemption

Bandwidth preemption is a function that stops a low priority connection so that a higher priority connection can use its resources. Bandwidth preemption is used:

- At connection setup
- On link failure
- On bandwidth increase request.

For more information on selecting a QoS with bandwidth preemption, see “High Priority (HPRI)” on page 11.

At Connection Setup

Preemption at connection setup is performed as follows:

1. A low-priority connection, without the non-disruptive path selection (NDPS) option, is established.
2. A request occurs to establish a new connection with a higher priority and there is not enough trunk capacity to support both connections at the same time.
3. The high-priority connection is established.
4. The low-priority connection is terminated and its resources (bandwidth and label) are released.

If the low-priority connection has the NDPS option, it is immediately rerouted with its initial mean bit rate. The connection is not terminated.

If the low-priority connection has the bandwidth adaptation (ADJ) option, it is rerouted with its initial mean bit rate, if possible.

If the new connection has the same priority as an established connection, and if there is not enough bandwidth available, the new connection is rejected.

After Link Failure

Preemption after link failure is performed as follows:

1. A low-priority connection without NDPS is established on a trunk. A connection with a higher priority is also established on the trunk.
2. The bandwidth capacity of the trunk becomes insufficient.
3. The high-priority connection is rerouted.
4. The low-priority connection is terminated and its resources are released.

If the low-priority connection has the NDPS option, it is immediately rerouted with its initial mean bit rate. The connection is not terminated.

If the low-priority connection has the bandwidth adaptation (ADJ) option, it is rerouted with its initial mean bit rate, if possible.

If there is not enough bandwidth available to reroute the high-priority connection, even when the low-priority connections are preempted, the high-priority connection is terminated and the low-priority connections are kept.

On Bandwidth Request

Preemption on bandwidth request is performed as follows:

1. A low-priority connection without NDPS is established on a trunk. A connection with a higher priority is also established on the trunk.
2. The high-priority connection requests more bandwidth and there is not enough bandwidth.
3. The high-priority connection gets the bandwidth.
4. The low-priority connection is terminated and its resources are released.
If the low-priority connection has the NDPS option, it is immediately rerouted with its initial mean bit rate. The connection is not terminated.
If the low-priority connection has the options bandwidth adaptation (ADJ) and bandwidth keeping (KEEP), it is rerouted with its initial mean bit rate, if possible.

If there is not enough bandwidth for the high-priority connection (even when adding the bandwidth of the low-priority connections):

- The high-priority connection is terminated while the low-priority connection continues to operate.
- If the high-priority connection has the KEEP option, its bandwidth remains unchanged and the bandwidth increase is rejected.

Bandwidth Management

Bandwidth management allocates a bandwidth that corresponds to users' needs. It is based on the connection parameters that define traffic characteristics and requested quality of service.

Allocating Bandwidth

The Nways Switch enforces fairness among users and provides low delay across the network. Accepting a request for a connection is a contract based on the connection parameters. This contract is a credit of network resources (mainly buffers) guaranteed for the duration of the connection.

When no data is transmitted on a given connection, it accumulates transmission credit, allowing the network to accept bursts of data at the port speed rather than at the assigned rate.

Network resources are reserved depending on the initial connection parameters. The 2220 network finds the best path to set the connection, then accepts the new connection by:

- Allocating the bandwidth needed to meet the terms of the contract, thus guaranteeing the requested QoS
- Smoothing this traffic flow, which may be bursty, by buffering data for each connection at the entry point to the network.

The combination of these two operations gives the *equivalent capacity* (E_c), which is the final amount of bandwidth reserved for each connection.

Leaky Bucket Policing

Once the allocated bandwidth is reserved, a policing process based on a *leaky bucket* algorithm ensures that the contract is respected. The leaky bucket behaves in the following way. Traffic bursts conforming to the contract are accepted using the transmission credit (*green traffic*) accumulated by the connection. When the transmission credit is exhausted, the traffic is considered as non-conforming, and one of the following process may occur:

- It is bufferized with a short delay.
- It becomes *red traffic* and enters the 2220 network where it is transmitted on a best effort basis.
- It is discarded.

Traffic Descriptors

Frame-relay bandwidth management uses either the frame-relay standard mode or the IBM value-added mode. Table 8 summarizes the valid combinations of traffic descriptors in both of these modes.

Table 8. Frame Relay Traffic Descriptors

Frame-Relay Standard Mode		IBM Value-Added Mode		
CIR Defined	CIR Null	NBBS Fixed Bandwidth	NBBS Bandwidth Adaptation	
			Without Limits	With Limits
AR CIR Bc Be	AR CIR=0 Bc (not used) Be	R m b	R m (initial) b (initial)	R m (initial) b (initial) Bandwidth min. Bandwidth max.
QoS without ADJ option			QoS with ADJ option	
Legend: AR Access rate (kbps) CIR Committed information rate (kbps) Bc Burst committed (bits) Be Burst in excess (bits) R Peak bit rate kbps m Mean bit rate (kbps) b Mean burst length (second)				
Note: For a further explanation of the parameters in the table, see the Frame-Relay Forum and ITU-T I-122 Recommendations.				

Bandwidth Modes

This section describes the bandwidth modes for frame-relay traffic:

- Fixed bandwidth (non-real-time)
- Bandwidth adaptation without limits (non-real-time)
- Bandwidth adaptation with limits (non-real-time)

- Frame-relay with CIR defined (non-real-time)
- Frame-relay with CIR null (non-real-time)
- Frame-relay real-time
- Frame-relay non-reserved.

Fixed Bandwidth

The parameters that define fixed bandwidth are as follows:

Peak bit rate (R)

Speed (in kbps) of the line that receives traffic from the user. This is the maximum throughput that the line can send to the access node.

Mean bit rate (m)

Average traffic (in kbps) received from the user.

Mean burst length (b)

Maximum duration (in seconds) of a burst of traffic received from the user at peak rate.

Quality of service (QoS)

In this mode, you select a predefined QoS without the bandwidth adaptation (ADJ) option.

These parameters define the amount of traffic expected. This value is used as the contract between the user and the 2220 network.

Allocated Bandwidth

Based on the contract, an equivalent capacity is computed according to the QoS defined for the connection. When you select a QoS with FRHDLCOption for a connection, the equivalent capacity is reserved as non-real-time traffic. All the trunks along the path as well as on the other side of the connection (also called *egress* port) are involved in this reservation. A first check is performed to ensure that the capacity is available. Other connections are prevented from using the bandwidth. Once the reservation is made, the leaky bucket algorithm starts.

Traffic That Conforms

Received traffic that conforms to the contract is accepted and sent through the 2220 network as green. Under normal conditions, green traffic is never discarded.

Traffic That Exceeds

Received traffic that exceeds the contract is handled by the leaky bucket algorithm in the following ways:

- Traffic that is 20% over the allocated bandwidth is accepted, marked in red, and sent to the 2220 network. Red traffic is never guaranteed and is transported if the trunks are not overloaded. When congestion occurs, red traffic is discarded.
- Traffic over the 20% mentioned above is discarded without entering the 2220 network.

Example

R = 64 kbps

m = 10 kbps

b = 0.01 second

QoS = QOSFRHDLCDPS.

The allocated bandwidth in the example is 10.04 kbps. This corresponds to the accepted green traffic if the burstiness does not exceed 0.01 second at 64 kbps. Two kbps of exceeding traffic is accepted as red. Traffic exceeding 12 kbps is discarded.

Bandwidth Adaptation Without Limits

The parameters that define bandwidth adaptation without limits are as follows:

Peak bit rate (R)

Speed of the line (in kbps) that receives traffic from the user. This is the maximum throughput that the line can send to the access node.

Initial mean bit rate (m)

Initial bandwidth (in kbps) to be allocated a connection setup. The bandwidth is reserved for the connection.

Initial mean burst length (b)

Maximum duration (in seconds) of a burst of traffic that is received at peak rate. In this mode, you configure an initial value of $4 \div R$. The value changes as the adapter dynamically changes the allocated bandwidth.

Quality of service (QoS)

In this mode, you configure a predefined QoS with the bandwidth adaptation (ADJ) option, and with or without the bandwidth keeping (KEEP) option.

Allocated Bandwidth

The initial mean bit rate is allocated first. As soon as the connection is set up, an adapter mechanism periodically:

- Analyzes the traffic received over a certain period of time.
- Compares received traffic to the configured QoS.
- Decides if the allocated bandwidth must be changed to fit the traffic received. The value of the reserved bandwidth varies from a few bits per second to the peak bit rate.

Bandwidth Increase/Decrease Granted by the Network

When the 2220 network grants a new contract that is dynamically computed by the adapter, all the received traffic should be accepted.

If some traffic exceeds the current contract, it is marked as red, and a new bandwidth is computed within the next seconds. During the bandwidth adaptation period, a wide bandwidth is assigned to the connection to accept red traffic.

Bandwidth Increase Not Granted by the Network

When the 2220 network cannot increase bandwidth for some reason (for example, because there is no more available bandwidth along the path), the non-disruptive path switching (NDPS) mechanism is attempted, if enabled by the QoS. If the required bandwidth still cannot be allocated at this time:

- If the bandwidth keeping option (KEEP) has not been selected, the connection is deactivated.

- If the KEEP option has been selected, the connection is kept active with the previously allocated bandwidth in a mode called *HDLC slow adaptation mode*. In this mode, to protect the 2220 network only 20% of red traffic is allowed. The connection returns to normal mode as soon as bandwidth adaptation has been successfully granted.

Example

R = 64 kbps

Initial m = 10 kbps

Initial b = $4 \div 64 = 1 \div 16$ second

QoS = QOSFRHDLCADJKEEPNDPS.

The initial allocated bandwidth in this example is 10 kbps. It dynamically varies from 100 bps to 64 kbps depending on the traffic received. It also depends on the 2220 network ability to allocate newly requested bandwidth.

Bandwidth Adaptation With Limits

The parameters that define bandwidth adaptation with limits are as follows:

Peak bit rate (R)

Speed (in kbps) of the line that receives traffic from the user. This is the maximum throughput that the line can send to the access node.

Initial mean bit rate (m)

Initial bandwidth (in kbps) to be allocated at connection setup. You define a value between the minimum bandwidth and the maximum bandwidth. The bandwidth is reserved to the connection along the link.

Initial mean burst length (b)

Maximum duration (in seconds) of a burst of traffic that is received from the user at peak rate. In this mode, you configure an initial value of $4 \div R$. The value changes as the adapter dynamically changes the allocated bandwidth.

Minimum bandwidth

Minimum bandwidth (in kbps) reserved even when no traffic is received. You must configure a minimum bandwidth smaller than the maximum bandwidth.

Maximum bandwidth

Maximum bandwidth (in kbps) that can be allocated to the connection. You must configure a maximum bandwidth smaller than or equal to the peak bit rate.

Quality of service (QoS)

In this mode, you select a predefined QoS with the bandwidth adaptation (ADJ) option, and with or without the bandwidth keeping (KEEP) option.

The maximum bandwidth and minimum bandwidth parameters are the limits for the bandwidth adaptation algorithm.

Allocated Bandwidth

The initial mean bit rate is allocated first. As soon as the connection is set up, an adapter mechanism periodically:

- Analyzes the traffic received over a certain period of time.
- Compares the received traffic to the configured QoS.

- Decides if the allocated bandwidth must be changed to fit the traffic received. The value of the reserved bandwidth varies from minimum bandwidth to maximum bandwidth.

Figure 3 displays parameters and bandwidth variations.

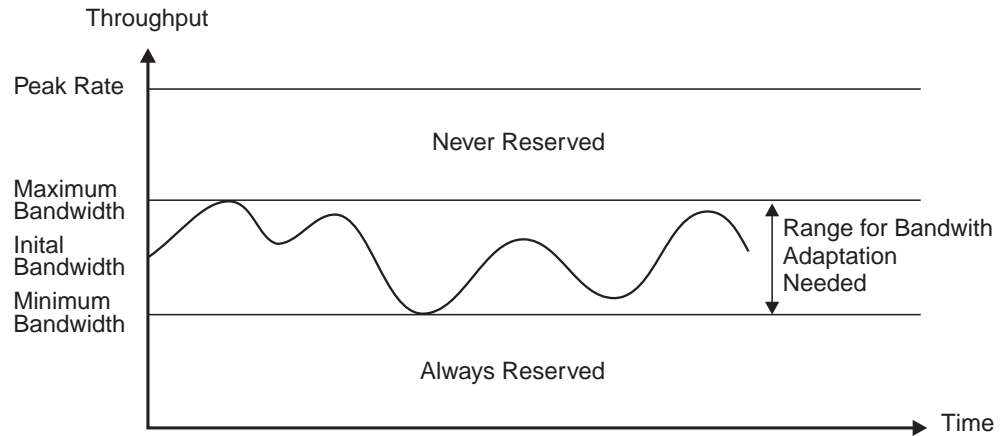

Figure 3. Bandwidth Adaptation

You can use the maximum bandwidth and minimum bandwidth parameters separately.

- Example 1:
 minimum bandwidth = 10 kbps
 maximum bandwidth = peak rate

This ensures minimum bandwidth reservation and bandwidth adaptation for traffic that exceeds the reserved bandwidth.

- Example 2:
 minimum bandwidth = 0
 maximum bandwidth = 20 kbps
 peak rate = 45 kbps

This ensures that the connection will never occupy all the available bandwidth. 25 kbps remain for the other connections.

When a bandwidth increase is not granted by the 2220 network, the connection enters slow adaptation mode as described in “Bandwidth Increase Not Granted by the Network” on page 24.

If the received traffic exceeds the maximum bandwidth, the adapter forces the new reservation to the maximum bandwidth and goes in *maximum bandwidth reached mode*. Since no more bandwidth can be allocated, the network must be protected against receiving more traffic.

In HDLC maximum bandwidth reached mode, only 20% of red traffic is allowed. This protects the network from having too much red traffic.

Maximum bandwidth reached mode is similar to slow adaptation mode except that:

- In maximum bandwidth reached mode, no more bandwidth can be allocated by a network operator.

- In slow adaptation mode, the bandwidth limitation originates with the 2220 network. Since new bandwidth can become available at any time (for example, due to bandwidth release by other connections, or new trunks activated), attempts to increase bandwidth are periodically performed.

The connection returns to normal mode as soon as a significant bandwidth decrease is performed.

Example

R = 64 Kbps
 Initial m = 10 kbps
 Initial b = $4 \div 64 = 1 \div 16$ second
 QoS = QOSFRHDLCADJKEEPNDPS
 Maximum bandwidth = 20 kbps
 Minimum bandwidth = 5 kbps

In this example, the initial allocated bandwidth is 10 kbps. It dynamically varies from 5 kbps to 20 kbps depending on the traffic received and depending on the ability of the 2220 network to allocate the newly requested bandwidth.

Frame-Relay with CIR Defined

The parameters that define frame relay with committed information rate (CIR) defined are:

Access rate (AR)

Speed (in kbps) of the line that receives traffic from the user. This is the maximum throughput that the line can send to the access node. In this mode, you configure AR as equal to the link speed.

Committed information rate (CIR)

Average traffic (in kbps) received from the user. In this mode, you configure CIR as different from 0.

Burst committed (Bc)

Maximum length (in bits) of a burst of traffic received from the user at peak rate. In this mode, you configure Bc as different from 0.

Burst in excess (Be)

Maximum length (in bits) of a burst of traffic in excess. Traffic above Bc+Be is not guaranteed and may be discarded.

Quality of service (QoS)

In this mode, you select a predefined QoS without the bandwidth adaptation (ADJ) option.

In this mode, the leaky bucket complies with frame-relay standards. These parameters define the expected traffic as a contract between the user and the 2220 network.

Allocated Bandwidth

Based on the contract, an equivalent capacity is computed depending on the QoS defined for the connection. When you select a QoS with FRHDLCOption for a connection, the equivalent capacity is reserved as non-real-time traffic. All the trunks along the path as well as on the other side of the connection (also called *egress* port) are involved in this reservation. A first check is performed to ensure that the

capacity is available. Other connections are prevented from using the bandwidth. Once the reservation is made, the leaky bucket algorithm starts.

Traffic That Conforms

Received traffic that conforms to the contract (CIR and Bc) is accepted and sent through the 2220 network as green traffic. This is, for example, the case when a burst of traffic does not exceed Bc at the access rate, assuming average traffic stays below CIR.

The throughput allowed for green traffic is given by the following formula:

$$\text{green traffic} = \text{CIR}$$

Under normal traffic conditions, green traffic is never discarded.

Traffic That Exceeds

Received traffic that exceeds the contract is handled by the leaky bucket algorithm in the following way:

- The traffic that exceeds Bc but is below Be is accepted and sent through the 2220 network as red traffic. Red traffic is never guaranteed and is transported if the trunks are not overloaded. When congestion occurs, red traffic is discarded.

The maximum throughput allowed for red traffic is given by the following formula:

$$\text{red traffic} = (\text{Be} - \text{Bc}) \times \text{CIR}$$

The red traffic ratio allowed above CIR is $\text{Be} \div \text{Bc}$. If Be is much higher than Bc, the traffic sent by the source will be marked red. If the trunks are overloaded or if large bursts are sent, the traffic is discarded. From an NBBS point of view (NDPS, call setup, or bandwidth increase), this does not impact other connections because the connection reservation (function of CIR) can be low while its throughput is high:

$$\text{CIR}(\text{green}) + \text{Be} - \text{Bc} \times \text{CIR}(\text{red})$$

This mode (wide Be) has the same characteristics as non-reserved traffic mode. If the user accepts a high traffic loss probability, this mode can be used because it limits the overload of NBBS mechanisms (NDPS, bandwidth increase, preemption) while permitting a large amount of traffic when the 2220 network is not overloaded.

- The traffic that exceeds Bc+Be is discarded without entering the 2220 network.

FECN and BECN Handling

The leaky bucket algorithm uses the forward explicit congestion notification (FECN) and backward explicit congestion notification (BECN). In data frames, FECN and BECN bits inform the sources to reduce their traffic when the allocated bandwidth is going to be reached. FECN and BECN are normally sent prior to any red-marking decision to allow a source that complies with FECN and BECN to transmit only green traffic. A source that does not comply may have its traffic marked in red or discarded.

Example

$$\text{AR} = 64 \text{ kbps}$$

$$\text{CIR} = 5 \text{ kbps}$$

$$\text{bc} = 6000 \text{ bits (maximum burst size accepted as green traffic)}$$

$$\text{be} = 60\,000 \text{ bits (Be} \div \text{Bc} = 10)$$

QoS = QOSFRHDLCDPS.

The allocated bandwidth in the example is 5.2 kbps. This corresponds to the accepted green traffic if the burstiness does not exceed 6000 contiguous bits at 64 kbps. 10x5 kbps of additional traffic is accepted as red, but traffic exceeding the sum of green and red throughputs is discarded. Therefore, up to 5 kbps + 50 kbps could be accepted (but limited to the access rate). This connection has 5.2 kbps reserved but can send 55 kbps, which will be accepted by the 2220 network if trunks are not overloaded.

Frame-Relay with CIR Null

The parameters that defined frame-relay with committed information rate (CIR) null are:

Access rate (AR)

Speed (in kbps) of the line that receives traffic from the user. This is the maximum throughput that the line can send to the access node. In this mode, you configure AR as lower than or equal to the link speed.

Committed information rate (CIR)

Average traffic (in kbps) received from the user. In this mode, you configure CIR as null.

Burst committed (Bc)

Maximum length (in bits) of a burst of traffic received from the user at peak rate. In this mode, you configure Bc as null.

Burst in excess (Be)

Maximum length (in bits) of a burst of traffic in excess. Traffic above Bc+Be is not guaranteed and may be discarded.

Quality of service (QoS)

In this mode, you select a predefined QoS without the bandwidth adaptation (ADJ) option.

Allocated Bandwidth

No reservation is made.

Traffic Accepted

Received traffic up to the configured access rate (AR), which is lower than or equal to the line speed, is accepted as red. Burst in excess (Be) specifies the maximum size of the received frames.

Traffic That Exceeds

Received traffic that exceeds AR is rejected. This case will not occur if you defined AR as the line access rate.

FECN and BECN Handling

FECN and BECN are never sent since this mode constitutes a best-effort service.

Example

AR = 45 kbps

CIR = 0 kbps

bc = 0 bits

be = 12 000 bits
QoS = QOSFRHDLCDPS.

On the average, red traffic, in the example, is accepted at speeds of up to 45 kbps. If AR is set lower than the link speed, the burst is limited to Be (12 000 contiguous bits in this example).

Frame-Relay Real-Time

The Nways Switch supports real-time traffic over frame-relay (and HDLC) connections in real-time class 2 (RT2). Voice is transported in real-time with a low transport delay.

Real-time traffic in frame relay allows assigning priorities among different types of traffic. RT2 packets have a higher priority than non-real-time traffic (NRT) and non-reserved (NR) in the whole transport process (policing, input queues, and output queues). Real-time and non-real-time connections can be mixed over the same frame-relay port line. Real-time in frame-relay also improves the quality of voice communications.

When configuring a connection for real-time traffic, you select a predefined quality of service (QoS) from “QoS for FR Real-Time Traffic” on page 12 depending on the desired options. Although these QoSs apply to frame-relay, they are taken from the CES QoS series and their name begin with QOSCESDATA. They provide a real-time class 2 (RT2) connection.

- On every low-speed connection, an outbound queue handles the traffic classes.
- On high-speed connections (associated with an high-speed adapter), there is a single outbound queue that handles the traffic. The bandwidth usage must be 50% of the link capacity. Also it is recommended to set an undersubscription of 50%.

The following constraints are related to frame-relay real-time traffic:

- Jitters induced on RT1 queue
- Large equivalent capacity.

Jitters Induced On RT1 Queue

Non-real-time flow is preempted by real-time traffic in order to limit jitters and delays. However, a real-time class 1 (RT1) packet may wait until the end of the transmission of an RT2 packet. To minimize the delay induced on RT1 packets, RT2 packet must be limited to a size of **128 bytes**.

On 128 kbps links, the maximum jitter per Nways Switch is 8 ms. Real-time frame-relay packets longer than 128 bytes are discarded by input port adapters.

Wide Equivalent Capacity

The equivalent capacity assigned to a connection is highly dependent on buffer size and loss priority. The smaller the buffers are, the larger the equivalent capacity is. This will limit the number of connections and will reduce the probability to congest output buffers. RT2 buffers are very small while NRT buffers are 256 KB.

To limit packet loss on frame-relay real-time connections, it is recommended to reserve a large bandwidth even when traffic is small. The equivalent capacity parameters must be input with precision. With small buffers, the equivalent capacity

is very sensitive. A small difference in the mean burst length (b) may induce important changes in bandwidth reservation. Also remember that b is a mean value and that wider bursts (for example, ten times larger) are likely to happen.

In the case of voice traffic from frame-relay access devices (FRADs), the burst size does not vary and is equivalent to packet size. Configuring b equal to FRAD packet size is pessimistic because this induces a reservation higher than required. It assumes that bursts much wider than the mean burst length can occur, which is not the case with FRAD voice traffic. For FRAD packets of 60 to 100 bytes, for example, mean burst size can be 10 to 20 bytes.

Frame-Relay Non-Reserved

The Nways Switch supports non-real-time frame-relay flow in non-reserved (NR) mode. To configure FR non-reserved connections, use the predefined QoSs listed in “QoS for FR Non-Reserved Traffic” on page 13 and the frame relay traffic parameters: AR, CIR, Bc, and Be.

Each connection has a minimum reservation that is specified by the FR parameters and is able to transport additional traffic up to the access rate (AR) value which must be lower than or equal to the line speed. To have the smallest reservation (0.1 kbps), specify a very small committed information rate (CIR) or even CIR=0.

The non-reserved flow uses the NR queue which has the lowest priority. Non-reserved traffic is sent only when no traffic is present on the other queues (RT1, RT2, and NRT).

Bandwidth is affected to non-reserved flow depending on the required CIR, but with no guarantee. Moreover, there is no flow control on the traffic accepted that exceeds the bandwidth reserved. The traffic may be discarded due to congestion. No message about the discarded traffic is sent to the traffic source.

At leaky bucket level, policing is done depending on the access rate (AR) which is lower than or equal to the line speed and the burst in excess (Be). If the input traffic conforms to AR, it is accepted. If it does not, a backward explicit congestion notification (BECN) is sent when 1/4 of Be depletion is reached.

Using non-reserved frame-relay traffic is a way to differentiate two types of non-real-time data traffic, such as SNA and IP traffics. Configure the SNA connection as non-real-time frame-relay while you configure the IP connection as non-reserved frame-relay. Then, IP traffic has no impact on SNA traffic. Even without flow control on non-reserved traffic, as long as there is no congestion, packet loss is low and network throughput is correct.

Selecting Bandwidth Mode

This section contains recommendations about which bandwidth mode to select according to your traffic characteristics. The recommendations apply in most cases. Depending on your network, however, you may have to select other modes to optimize network use.

Traffic Complying with FECN/BECN

SNA traffic is an example of traffic that complies with forward and backward explicit congestion notification (FECN and BECN). The following modes are recommended:

- Fixed bandwidth
- Bandwidth adaptation without limits
- Bandwidth adaptation with limits.

For sources that comply with FECN and BECN, the leaky bucket algorithm provides the allocated bandwidth for green traffic. FECN and BECN bits handled by the adapters provide guidance for stabilizing the source at optimum green traffic throughput. Avoiding the use of red traffic provides the appropriate quality of service, since green traffic is rarely discarded under normal network conditions.

Traffic Not Complying with FECN/BECN

Router traffic is an example of traffic that does not comply with forward and backward explicit congestion notification (FECN and BECN). The following modes are recommended:

- Frame relay with CIR defined
- Frame relay with CIR null
- Non-reserved.

For sources that do not comply with FECN and BECN bits, accepting a wide amount of red traffic allows bursts in IP traffic to be absorbed, as long as the path is not fully loaded. When the path is fully loaded, discarding occurs and applications must be retried.

While red traffic is limited to a few bytes in the adapter output queues, non-reserved traffic can use 256 kbytes queues which absorb wider bursts. For router traffic, non-reserved mode is the preferred choice compared to CIR=0 . This choice also guarantees that other non-real-time flows with higher priority are not penalized.

Example: SNA and IP Traffic Merge with Priority on SNA

In this example, the SNA traffic has a higher priority than the IP traffic.

- SNA traffic has bandwidth adaptation in limits mode:

R = 64 kbps

Initial m = 10 Kbps

Initial b = $4 \div 64 = 1 \div 16$ second

QoS = QOSFRHDLCADJKEEPNDPS

Maximum bandwidth = 35 kbps

Minimum bandwidth = 5 kbps

1. IP traffic is frame-relay in non-reserved mode:

- AR = 64 kbps
- CIR = 0 kbps
- Bc = (not used)
- Be = (not used)
- QoS = QOSFRHDLNCRNDPS.

Local Management Interface (LMI)

The local management interface (LMI) operates on the data link connection identifier (DLCI) 0 and informs the frame-relay DTE about the status and configuration of the permanent virtual circuits (PVCs) in the access channel.

The LMI is a set of procedures and messages defined to operate at one of the following interfaces:

- Between a user device and a frame-relay network at the user network interface (UNI)
- Between two frame-relay networks at the network node interface (NNI).

Information frames are exchanged using unnumbered information (UI). The LMI supports synchronous exchange of statuses between the user side and the 2220 network. The Nways Switch is also able to send asynchronous messages to report changes in a PVC status.

User Network Interface (UNI)

UNI local management complies with ANSI T1.617 Annex D and ITU-T Q.933 Annex A for permanent virtual circuits (PVCs). Messages are made up of several information elements (IEs) which vary depending on the message types.

Network Node Interface (NNI)

NNI support constitutes a bidirectional UNI. The network node is user side and network side at the same time. In this case, N392 and N393 are both defined with the same value for the count of user side errors and network side errors but both counters must be defined.

Information Elements (IEs)

Table 9. LMI Information Elements

Type of Information Element (IE)	Contents
Protocol discriminator	0x08
Call reference	0x00
Message type	Enquiry: 0x75 Status: 0x7D
Locking shift (used only in ANSI format)	0x95

Several IEs are described in the following sections. They are preceded by an identifier byte and a length of contents byte. As explained below, ANSI and ITU-T formats differ slightly.

Status Enquiry Message

Figure 4 on page 34 shows the LMI message sent from the user side to request link integrity verification (LIV request) or periodical VC status request from the network side.

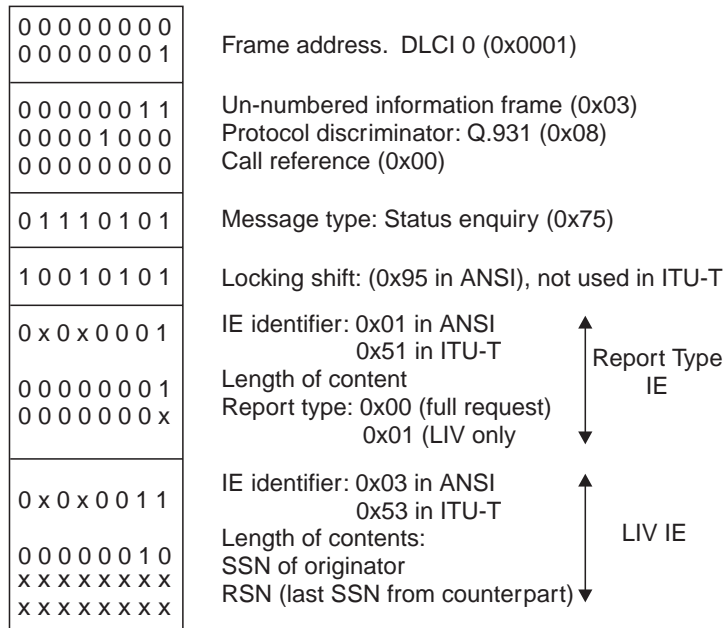

Figure 4. Status Enquiry from the User Side

LIV Status Message

Figure 5 shows an LMI message sent from the network side in response to a LIV status enquiry asking if the port is active.

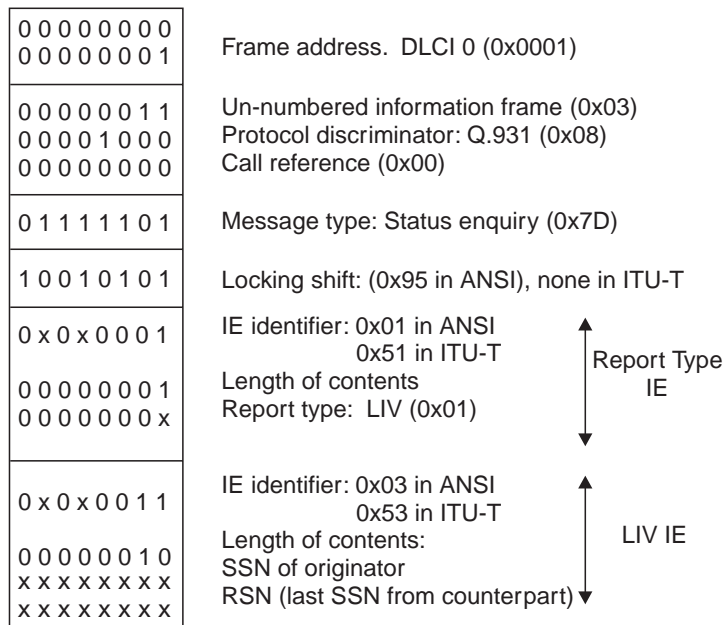

Figure 5. LIV Status Answer from Network Side

Full Status Message

Figure 6 on page 35 shows an LMI message sent from the network side in response to a full status enquiry asking if the port is active. The message gives the

status of all virtual circuits (VCs) on the port. These are end-to-end statuses telling the user side about the status of the entire frame-relay VC.

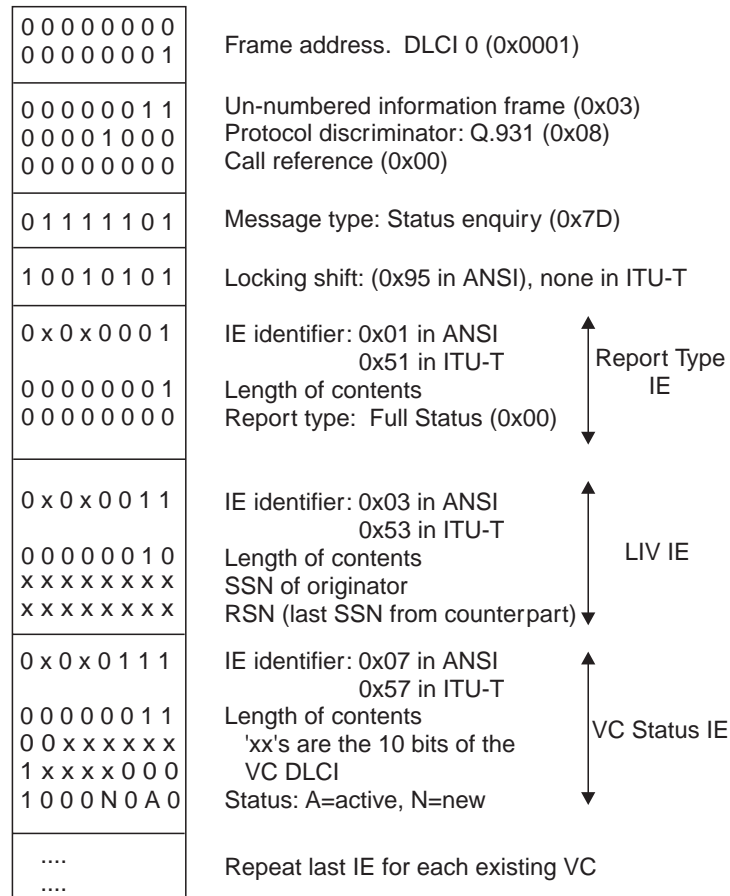

Figure 6. Full Status Answer from Network Side

Asynchronous Status Message

Figure 7 on page 36 shows an LMI message sent asynchronously from a network node to inform the user side of an event on a specific virtual circuit. Examples of such events are VCs that become active, inactive, or that have been deleted.

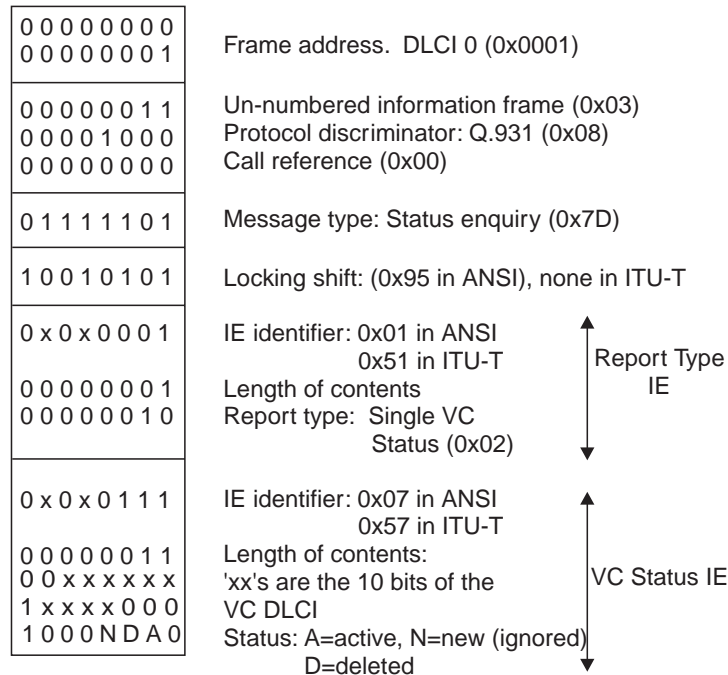

Figure 7. Asynchronous Status Notification from Network Side

LMI Procedures

This section summarizes the rules for message exchange between the user and network sides as shown in Figure 8 on page 37.

Link Integrity Verification (LIV)

To verify that a physical link supporting virtual circuits is still active and functional, the user side of the connection exchanges message sequence numbers with the network side at pre-defined polling interval (T391 timer).

The user side sends a status enquiry message at each T391 interval. The report IE tells the network side that this is a LIV status request. The LIV information element contains a send sequence number (SSN) and a receive sequence number (RSN), which is the last SSN received from the other side. These numbers are updated at each exchange to detect any message loss.

The network side must answer by a status message containing a LIV information element (for example, the sequence numbers identifying the message) before receiving the next enquiry. A full status response is also supported, since it contains the LIV information element.

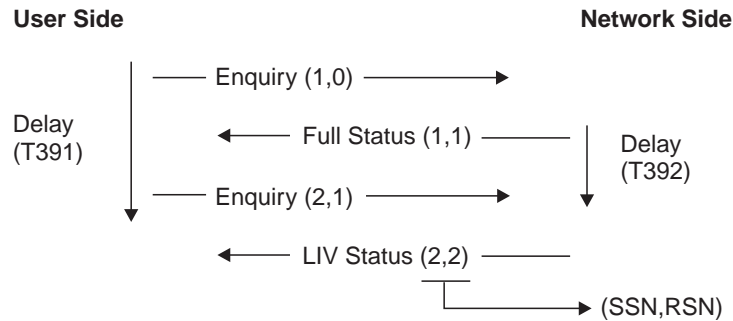

Figure 8. LMI Procedure and Timing

Note: Initial values are 1 for SSN and 0 for RSN.

If one of the following events happens, an error is recorded at the user side:

- Response not received within the T391 timer after the enquiry has been sent.
- Response in wrong format.
- RSN of status not matching the SSN of the last enquiry.

If one of the following events happens, an error is recorded at the Nways Switch side:

- Enquiry not received within the T392 timer after the status has been sent.
- Status enquiry in wrong format.
- RSN of enquiry not matching the SSN of the last status.

Each side maintains an error counter. If the threshold defined in the LMI parameters is reached, an LMI Service Affected condition is reported and all the virtual circuits segments are set to *inactive* status. Normal operation resumes when the condition disappears.

If there is a wrong format or if the RSN does not match the last SSN, the error is recorded after a timeout. If the right response is received in the meantime, the error counter is not updated. This avoids counting the same error twice.

Notification of Full VC Status (Mandatory)

Once every N391 polling, the user side requests a full status. The status request is the same as above, except for the report IE which is a full status request.

The responding message must be a full status that provides the status of all VCs on the port and that contains a LIV information element with the sequence numbers.

Each time a VC is created, the network side assigns a DLCI to the new VC and sets the new (N) bit in the messages. Even if the status IE is lost, the user side by detecting the N bit in the messages is aware that the VC is new. The network side will not reset the N bit until, using the sequence numbers, it knows that the messages are correctly received at the user side.

Asynchronous Support

Asynchronous support allows the network side to send an unsolicited VC status. The message informs the user side that a VC has become active, inactive, or has been deleted, without waiting for the timeout. The message does not perform a link

integrity verification. If the user side does not support it, the message is discarded. There is no asynchronous message for a new VC to avoid a mismatch between the new VC and an old VC.

The unsolicited VC status is not acknowledged. If it is not received by the user side (because it is not supported or lost), the next full status informs the user side of the change.

Bidirectional Support (Optional)

Bidirectional support allows both the user and network sides of a connection to support LMI procedures at the same time. Separate sequence numbers and counters coexist on each side. This allows an NNI to exist so that both sides get information about the other side of the VC.

Congestion Management

In an 2220 network you deal with congestion at two levels. One is the connection level (policing), the other is the physical adapter level (global and severe adapter congestions).

Policing Connections

Each connection is subject to a contract between the user and the network in terms of traffic characteristics. The traffic is checked when entering the 2220 network and is declared either:

- Conforming (green) for the traffic that stays within the allocated bandwidth
- Non-conforming (red) for the traffic in excess.

Red traffic is allowed to enter the 2220 network if there are enough resources to handle it, but it may be discarded at any intermediate stage if there are not enough resources.

Policing is performed in the following modes:

- Frame-relay standard mode:
 - All traffic below Bc is transmitted and marked as green.
 - Traffic between Bc and Bc+Be is transmitted as either green or red independently of the discard eligibility (DE) bit.
 - The traffic in excess (above Bc+Be) is not guaranteed and may be discarded. The FECN and BECN bits are set (if not already set by the user) for all frames of connections involved in congestion.

Note: No selective discarding is done based on the DE bit in the incoming frames.

- IBM value added mode:

In this mode, the bandwidth adaptation (ADJ) option is used to set the minimum and maximum values of the bandwidth for each connection (the minimum bandwidth can be set to 0). During bandwidth adaptation, the FECN and BECN bits are not set by the network side.

After a bandwidth increase request, if the bandwidth increase is not granted or if the maximum bandwidth is reached, the connection is terminated and the frames are discarded. The FECN and BECN bits are set for the corresponding DLCI.

If the maximum bandwidth is not reached, the network takes one of the following actions depending on the QoS option that you configured:

- If the ADJ option has been configured, the network tries to obtain the bandwidth on the existing path.
- If the KEEP option has been configured, the network keeps the connection and discards part of the traffic until the bandwidth can be successfully increased. The last bandwidth value allocated is kept.
- If the NDPS option has been configured, the network tries non-disruptive path switching.
- If none of the actions above can be done, the network terminates the connection and discards the frames.

Traffic is handled in the same way no matter how the DE bit is set from the user side.

Global Adapter Congestion

Global adapter congestion occurs when the pool of resources and buffers available on the adapter reaches a certain threshold, or if a significant amount of red traffic is sent over the network. For all supported connections, the congested adapter:

- Sets the FECN and BECN bits (if they are not already set in the user frames).
- Discards the incoming frames that have the DE bit set.

Global adapter congestion prevents severe congestion provided that the user side reacts to the FECN and BECN bits.

Severe Adapter Congestion

Severe adapter congestion occurs when there are no more resources available on the adapter. All incoming frames are discarded. This can occur when a significant amount of red traffic is sent over the network.

Chapter 4. ATM / Frame Relay Interworking

Overview

The IBM 2220 supports two types of interworking between Frame Relay and ATM devices, according to ITU-T Recommendation I.555:

Network Interworking (NIWF)

Two Frame Relay devices communicating over an ATM network.

Service Interworking (SIWF)

A Frame Relay device communicating with an ATM device, where neither device knows that the other device is connected using a different protocol.

Note: Service interworking is limited to the set of higher-layer protocols currently supported by RFC 1483 and RFC 1490, while network interworking is transparent to higher-layer protocols. This means, for example, that voice packets carried over Frame Relay could be handled by the NIWF, but not by the SIWF.

Network Interworking

Two scenarios are defined in ITU-T Recommendation I.555 for the network interworking function (NIWF):

Scenario 1

Where two Frame Relay CPEs (Customer Premises Equipment) are connected across an ATM network.

Scenario 2

Where a Frame Relay network or terminal is connected to an ATM terminal across an ATM network.

These scenarios are described in the following sections.

NIWF: Two Frame Relay Devices

In this scenario, the use of the ATM network is invisible to the two Frame Relay CPEs. The NIWF provides all mapping and encapsulation functions necessary to ensure that the service provided to the Frame Relay CPEs is unaffected by the presence of ATM transport. Figure 9 shows a typical configuration using this scenario, and illustrates the protocol suites associated with the corresponding user plane.

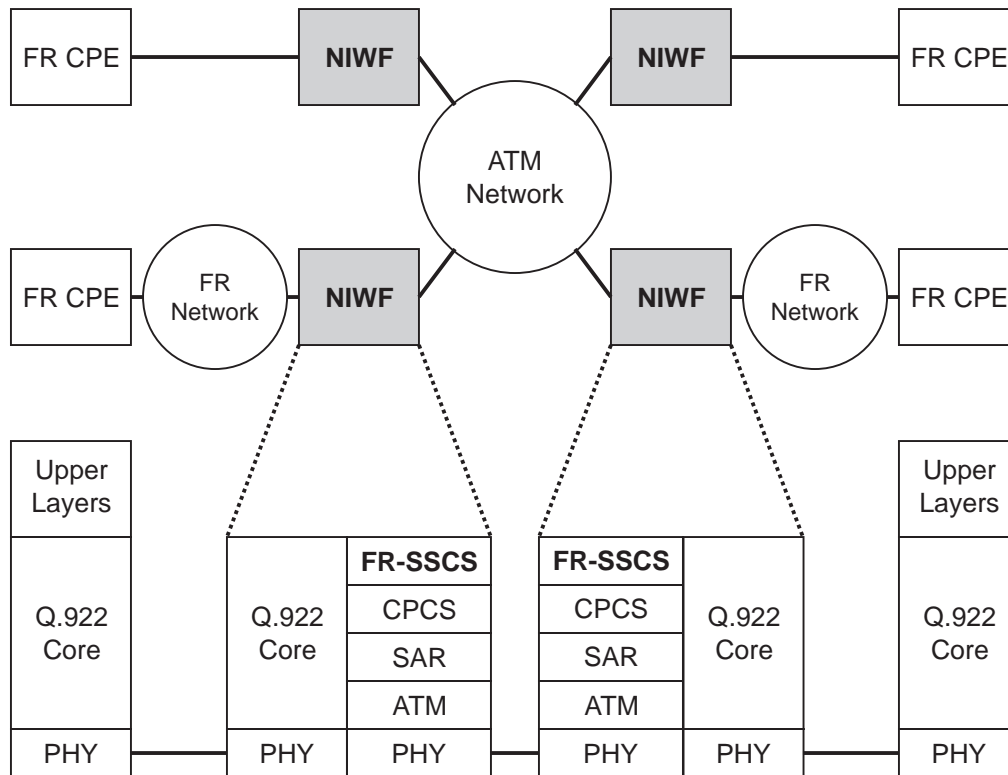

Figure 9. Network Interworking with Two Frame Relay Devices

NIWF: Frame Relay and ATM Devices

In the second scenario, the Frame Relay CPE is unaware of the use of the ATM network, as shown in Figure 10. The ATM CPE must support the Frame Relay Service Specific Convergence Sublayer (FR-SSCS) in its protocol stack. The NIWF is the same as in the first scenario.

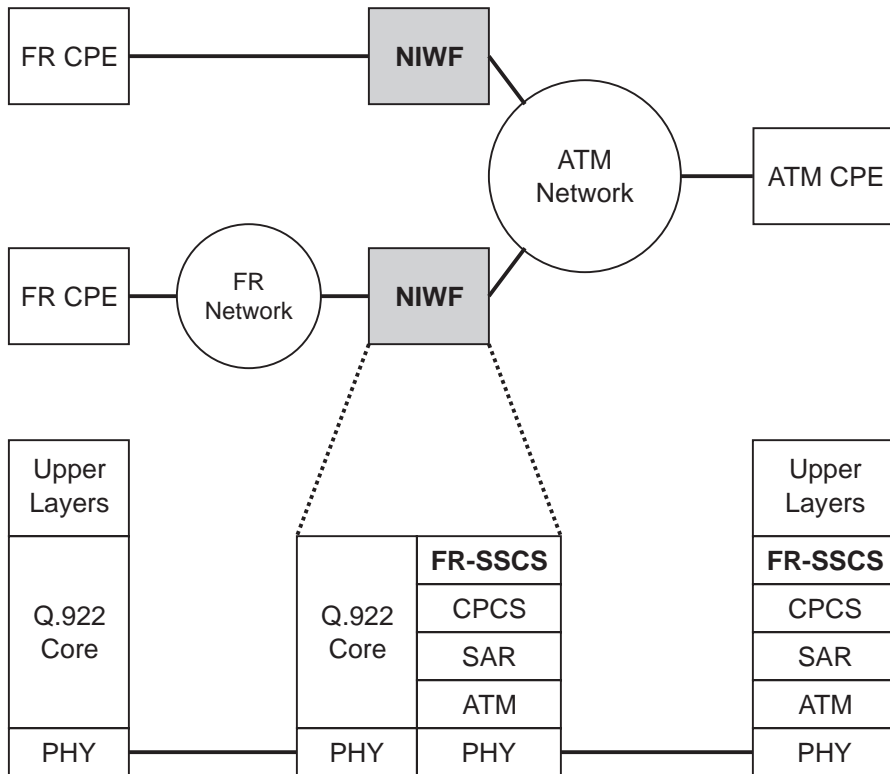

Figure 10. Network Interworking with a Frame Relay Device and an ATM Device

NIWF Example

The example shown in Figure 11 shows a network configuration where network interworking is used to connect Frame Relay terminal equipment through heterogeneous networks. In this case compliance to the FRF.5 standard allows interoperation with equipment from other manufacturers.

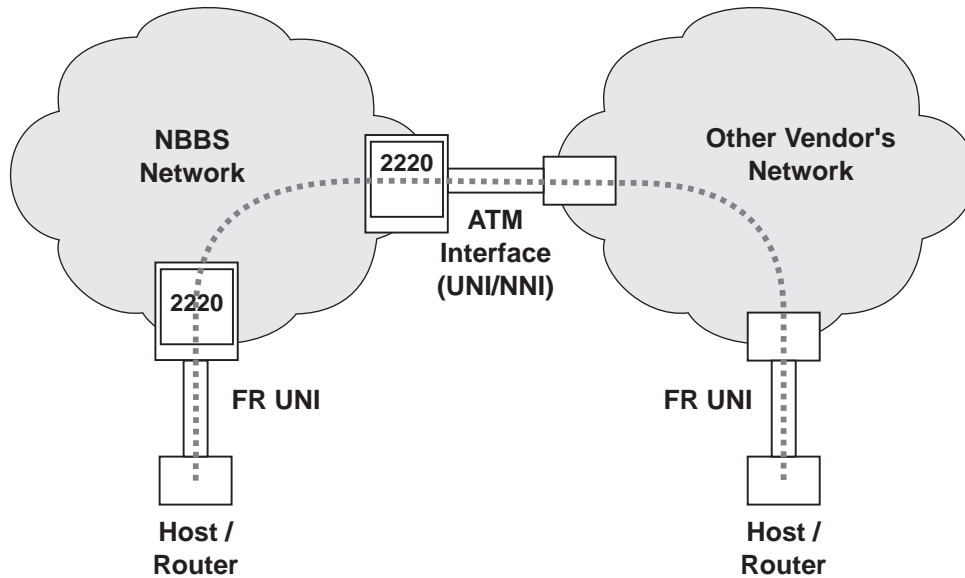

Figure 11. Network Interworking Function Example

Service Interworking

In service interworking, a Frame Relay network or CPE interworks with an ATM CPE. The ATM CPE performs no Frame Relay-specific functions, and the Frame Relay CPE performs no ATM-specific functions. All interworking functions are performed by the Service Interworking Function (SIWF). Since multiprotocol encapsulation schemes are different over Frame Relay (RFC 1490) than over ATM AAL5 (RFC 1483), some protocol translation may need to be performed by the SIWF.

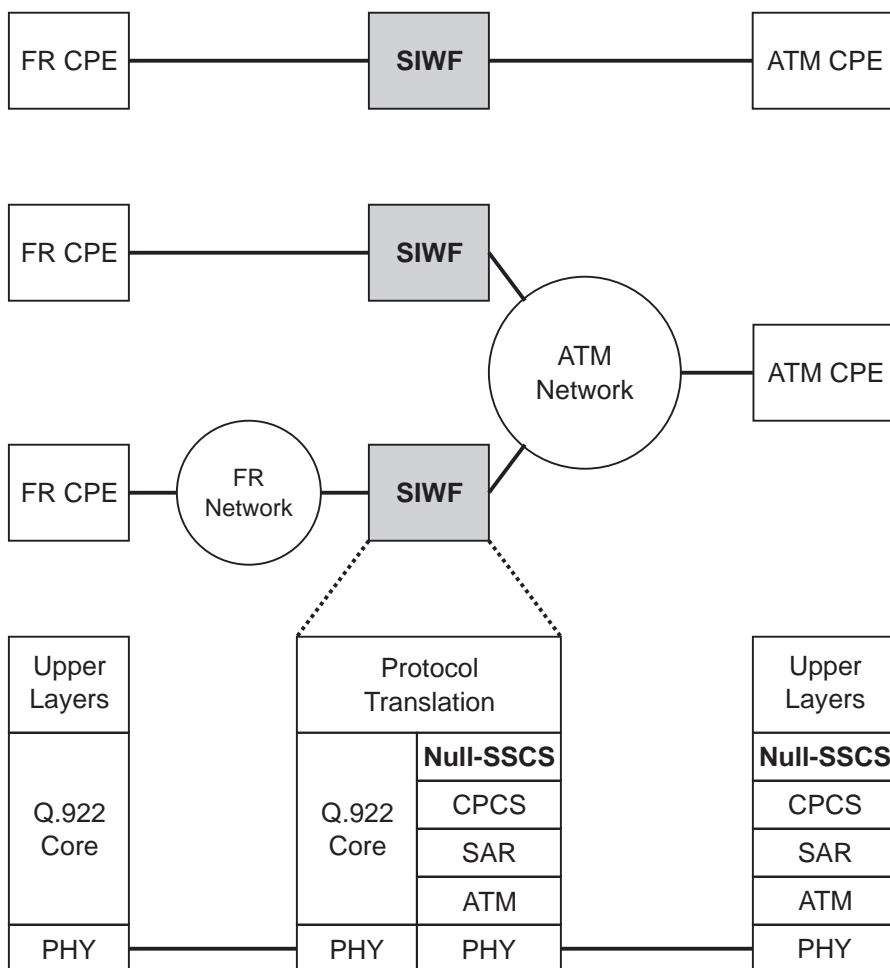

Figure 12. Service Interworking

SIWF Example 1

Figure 13 shows an IP router connected to an NBBS network through a Frame Relay UNI. A Web server supporting Classical IP is connected to the same network through an ATM UNI. From an IP point of view, they appear adjacent.

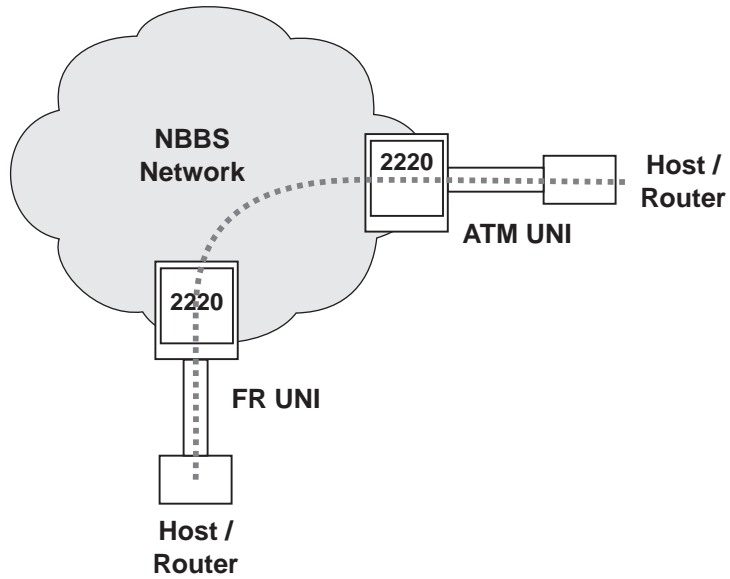

Figure 13. SIWF Example 1

SIWF Example 2

Since the SIWF is compliant with the FRF.8 standard, either the Frame Relay DTE or the ATM DTE could be connected to equipment from a different manufacturer, as shown in Figure 14.

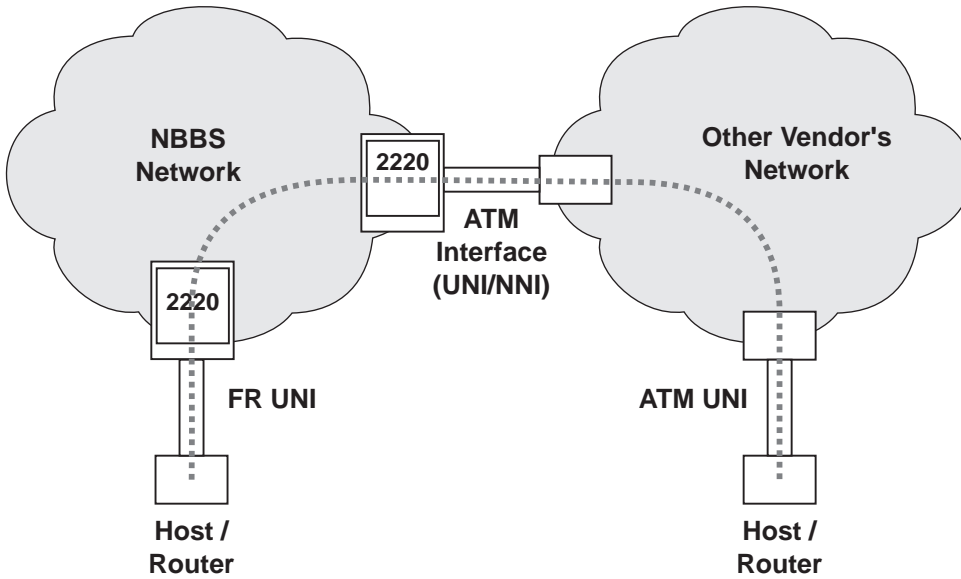

Figure 14. SIWF Example 2

Interworking Specifications

- Interworking (both NIWF and SIWF) run only on the LSA3 adapter.
- The Nways Switch Frame Relay access agent only supports 2-byte Q.922 core header (i.e., 10-bit DLCI values).
- The Network Interworking and the Service Interworking functions are part of the Frame Relay Access Agent located in the Frame Relay port adapter.
- NIWF and SIWF comply with the corresponding FRF.5 and FRF.8 Implementation Agreements.
- Connection multiplexing is limited to one-to-one mapping in both Network Interworking and Service Interworking.
- A Frame Relay port can simultaneously support NBBS FR transport, NIWF, and SIWF. The mode of transport is selected at FR PVC level according to configuration parameters.
- For both network and service interworking connections the FR Access Agent appears as an ATM Access Agent to its remote partners.
- ATM Frame Relay interworking connections are PVC only.
- Connections are configured on the Frame Relay side.
- CBR , VBR and UBR traffic are supported.
- Only standard Frame Relay traffic parameters are supported for configuring interworking connections. The use of NBBS traffic parameters is restricted to connections configured for NBBS transport.
- The SIWF supports higher layer protocol conversion (i.e., 1490/1483 conversion). The following protocols are supported: IP, IPX, Q.933, ISO SNAP, bridged PDUs, X25 , ISO 8208 PDUs and FRF.9 compressed PDUs.
- 'Frame Relay ATM Interworking' is also available in 'Frame relay over ISDN' mode.
- Bandwidth adaptation is not supported in 'Frame Relay ATM Interworking'

Appendix. Notices

Notices

References in this publication to IBM products, programs, or services do not imply that IBM intends to make these available in all countries in which IBM operates. Any reference to an IBM product, program, or service is not intended to state or imply that only IBM's product, program, or service may be used. Any functionally equivalent product, program, or service that does not infringe any of IBM's intellectual property rights may be used instead of the IBM product, program, or service. Evaluation and verification of operation in conjunction with other products, except those expressly designated by IBM, is the user's responsibility.

IBM may have patents or pending patent applications covering subject matter in this document. The furnishing of this document does not give you any license to these patents. You can send license inquiries, in writing, to the IBM Director of Licensing, IBM Corporation, 500 Columbus Avenue, Thornwood, New York 10594, U.S.A.

European Union (EU) Statement

This product is in conformity with the protection requirements of EU Council Directive 89/336/EEC on the approximation of the laws of the Member States relating to electromagnetic compatibility. IBM can not accept responsibility for any failure to satisfy the protection requirements resulting from a non-recommended modification of the product, including the fitting of non-IBM option cards.

Year 2000 Statement

This product is Year 2000 ready. When used in accordance with its associated documentation, it is capable of correctly processing, providing, and/or receiving date data within and between the 20th and 21st centuries, provided all other products (for example, software, hardware, and firmware) used with the product properly exchange accurate date data with it.

For more information, refer to:

<http://www.ibm.com/year2000>

Electronic Emission Notices

Federal Communications Commission (FCC) Statement

Note: This equipment has been tested and found to comply with the limits for a Class A digital device, pursuant to the Part 15 of FCC Rules. These limits are designed to provide reasonable protection against harmful interference when the equipment is operated in a commercial environment. This equipment generates, uses, and can radiate radio frequency energy and, if not installed and used in accordance with the instruction manual, may cause harmful interference to radio communications. Operation of this equipment in a residential area is likely to cause harmful interference, in which case the user will be required to correct the interference at his own expense.

Properly shielded and grounded cables and connectors must be used in order to meet FCC emission limits. IBM is not responsible for any radio or television interference caused by using other than recommended cables and connectors or by unauthorized changes or modifications to this equipment. Unauthorized changes or modifications could void the user's authority to operate this equipment.

This device complies with Part 15 of the FCC Rules. Operation is subject to the following two conditions: (1) this device may not cause harmful interference, and (2) this device must accept any interference received, including interference that may cause undesired operation.

Industry Canada Compliance Statement

This Class A digital apparatus complies with Canadian ICES-003.

Avis de conformité aux normes d'Industrie Canada

Cet appareil numérique de la classe A est conforme à la norme NMB-003 du Canada.

Japanese Voluntary Control Council for Interference (VCCI) Statement

This product is a Class A Information Technology Equipment and conforms to the standards set by the Voluntary Control Council for Interference by Information Technology Equipment (VCCI). In a domestic environment this product may cause radio interference in which case the user may be required to take adequate measures.

この装置は、情報処理装置等電波障害自主規制協議会（VCCI）の基準に基づきクラスA情報技術装置です。この装置を家庭環境で使用すると電波妨害を引き起こすことがあります。この場合には使用者が適切な対策を講ずるよう要求されることがあります。

Harmonics Compliance (JEIDA)

This product conforms to the Harmonics Guideline (JEIDA). The input current of this product is less than or equal to 20 A per phase.

Korean Communications Statement

Please note that this device has been certified for business use with regard to electromagnetic interference. If you find this is not suitable for your use, you may exchange it for one of residential use.

Taiwanese Class A Warning Statement

This is a Class A product. In a domestic environment this product may cause radio interference in which case the user will be required to take adequate measures.

警告使用者：
這是甲類的資訊產品，在居住的環境中使用時，可能會造成射頻干擾，在這種情況下，使用者會被要求採取某些適當的對策。

Trademarks and Service Marks

The following terms, denoted by an asterisk (*), used in this publication, are trademarks or service marks of IBM Corporation in the United States or other countries:

IBM
OS/2
NetView
Nways

The following terms, denoted by a double asterisk (**), used in this publication, are trademarks of other companies as follows:

Accunet

American Telephone and Telegraph

AT&T American Telephone and Telegraph

IDNX Network Equipment Technologies, Incorporated

Microsoft Windows

Microsoft Corporation

Bibliography

This section lists prerequisite and related publications.

Nways Switch Publications

- *2220 Nways BroadBand Switch At a Glance, an Overview*, GA33-0292
- *2220 Nways BroadBand Switch Planning Guide*, GA33-0293
- *2220 Nways BroadBand Switch Configuration Guide*, GA33-0474
- *2220 Nways BroadBand Switch Physical Lines Interface Specifications, External Cable References*, GA33-0379
- *2220 Nways BroadBand Switch Frame Relay Interface Specifications*, GA33-0374
- *2220 Nways BroadBand Switch HDLC Interface Specifications*, GA33-0375
- *2220 Nways BroadBand Switch CES Interface Specifications*, GA33-0376
- *2220 Nways BroadBand Switch ATM Interface Specifications*, GA33-0378
- *2220 Nways BroadBand Switch X.25 Interface Specifications*, GA33-0413
- *2220 Nways BroadBand Switch ISDN Interface Specifications*, GA33-0447
- *How to use the NAS*, online tutorial¹

Nways 2220 Switch Manager Publications

- *IBM Nways 2220 Switch Manager for AIX Installation Guide*, SH11-3088
- *IBM Nways 2220 Switch Manager for AIX: Performance Monitoring and Accounting*, GA33-0366
- *IBM Nways 2220 Switch Manager User's Guide*, online manual²

TME 10 NetView for AIX Version 5 Publications

- *NetView for AIX Installation and Configuration*, SC31-8163

1. Online documentation delivered with the 2220 Nways Switch Control Program.

2. Online documentation delivered with the Nways 2220 Switch Manager product.

- *NetView for AIX V4R1 User's Guide*, SC31-8158

TMN 2.2 Publications

- *TMN 2.2 General Information*, GT01-0458
- *TMN 2.2 Agent User's Guide* SC31-8157

TME 10 Software Distribution Publications

- *Software Distribution for AIX Concepts*, GH19-4161
- *Software Distribution for AIX Getting Started*, GH19-4162
- *Software Distribution for AIX User's Guide*, GH19-4163
- *Software Distribution for AIX Installation and Customization*, GH19-4164
- *NetView Distribution Management Agent/2 User's Guide*, SH19-4084

OSI System Management Standards for CMIP

OSI stands for Open Systems Interconnection

OSI Management Framework and Overview

- *OSI Basic Reference Model Part 4: Management Framework* ISO 7498-4
- *Systems Management Overview* ISO 10040

CMIP/CMIS

- *Common Management Information Service Definition* ISO 9595

Systems-Management Functions

- *Part 1: Object Management Function*, ISO 10164-1
- *Part 2: State Management Function*, ISO 10164-2
- *Part 3: Attributes for Representing Relationships* ISO 10164-3
- *Part 4: Alarm Reporting Function*, ISO 10164-4
- *Part 5: Event Report Management Function*, ISO 10164-5

- *Part 9: Objects and Attributes for Access Control* ISO 10164-9
- *Accounting Management* , SC 21 N 4971
- *OSI Software Management* , SC 21 N 6040
- *General Relationship Model* , SC 21 N 6041
- *Performance Management* , SC 21 N 6306

Management Information Model

- *Part 1: Management Information Model* , ISO 10165-1
- *Part 2: Definition of Management Information* , ISO 10165-2
- *Part 5: Generic Managed Information* , ISO 10165-5

World Wide Web

You can access the latest news and information about IBM network products, customer service and support, and microcode upgrades on the IBM World Wide Web server, via Internet, at the URL <http://www.ibm.com>

Glossary

The following are the abbreviations and technical terms used in the 2220 Nways Switch library.

2220. The IBM 2220 Nways BroadBand Switch (also called Nways Switch) is a fast packet switch enabling high-speed communications over a broadband network. It implements the functions of the IBM Networking BroadBand Services (NBBS) architecture.

2220-300. 2220 Nways Switch Model 300.

2220-500. 2220 Nways Switch Model 500.

2220-501. 2220 Nways Switch Model 501.

2220 NSM. 2220 Nways Switch Manager

AAL. ATM adaptation layer.

ABR. Availability bit rate. A best effort service with a minimum bit rate and a maximum cell loss value.

ac. Alternating current.

access services. Functions that are performed by a port adapter of the IBM 2220 Nways BroadBand Switch to:

- Support the attachment of external user devices through port lines
- Prepare user data packets
- Control the input traffic on port lines
- Manage line protocols.

active remote connector (ARC). A connector that supplies the electrical and physical interfaces between a line interface coupler type 511 (LIC511) in an Nways Switch subrack and data circuit-terminating equipment (DCE) or data terminal equipment (DTE). ARCs are housed in line connection boxes (LCBs).

adapter. An Nways Switch module that can be used, depending on its hardware type and the code that it runs, as:

- Control point adapter
- Port adapter
- Trunk adapter
- Voice server adapter.

A trunk or port adapter is associated with a line interface coupler (LIC). A voice server adapter can be associated with a voice server extension (VSE).

ADPCM. Adaptive differential pulse code modulation.

AIS. Alarm indicator signal.

AIX. Advanced Interactive Executive.

alarm and power control (APC). In an Nways Switch, a module that connects the NAS, reports alarms, and controls the power supplies.

Alert Manager. An application that processes the SNA alerts received from IBM 3746s operating in IP mode.

AMI. Alternate mark inversion.

ANSI. American National Standards Institute.

APC. Alarm and power control (module).

AR. Access rate.

ARC. Active remote connector.

asynchronous transfer mode (ATM). A high-speed, connection-oriented switching and multiplexing protocol that transmits different types of traffic (voice, video, and data) simultaneously.

ATM. Asynchronous transfer mode.

ATMA_n. ATM adapter type n (module).

ATM adaptation layer (AAL). In ATM devices, a set of protocols that adapt non-ATM devices to an ATM network. There are several classes of ATM adaptation layers which represent the main traffic types (for example, data, voice, and video).

ATM network interface. A logical resource generated by the Nways Switch Control Program to provide access services to a physical ATM port or trunk line. An ATM network interface sets up and maintains predefined ATM virtual connections.

AT&T. American Telephone & Telegraph (Company).

B8ZS. Bipolar eight-zero substitution.

Bc. Burst committed.

Be. Burst in excess.

bearer service profile (BSP). A set of parameters that defines a type of ISDN traffic (speech, audio, data, or video). One BSP is associated with each ISDN numbering plan table.

BECN. Backward explicit congestion notification.

B-ICI. Broadband inter-carrier interface.

BMI. Byte multiplexer interface.

BNC. Bayonet Niell-Concelman.

bps. Bit per second.

bridge. A functional unit that interconnects two local area networks. A bridge works at the data link level (layer 2) of the OSI reference model.

broadband network. A network that uses a large frequency band to transport different kinds of traffic (such as coded voice, video, and data) at the same time.

BS. Bearer services.

BSC. Binary synchronous communication.

BSP. Bearer service profile.

BT. Burst tolerance.

bursty. Refers to transmission at variable bit rate where the time between data transmissions is not always the same.

CAC. Connection admission control.

CAS. Channel associated signaling.

CBR. Constant bit rate.

CCS. (1) Common channel signaling (2) Change control server (also called CC server).

CDB. Configuration database.

CDV. Cell delay variation.

CDVT. Cell delay variation tolerance.

cell loss priority (CLP). A priority bit in the ATM cell header. When set, it indicates that the cell can be discarded during traffic congestion.

centralized configuration database. A database prepared with the Nways Switch Configuration Tool Version 2 (NCT2) on a configuration station. It stores the parameters of a 2220 network.

CES. Circuit emulation services.

change control server (CCS or CC server). A station that runs the IBM NetView Distribution Manager for AIX to store the Nways Switch Control Program and to manage code changes.

CIR. Committed information rate.

circuit emulation services (CES). An access service that emulates a leased line. It transports information with a constant bit rate at the source and destination. The traffic can be PCM voice, video, fax, multimedia, or real-time synchronous data (such as BSC).

CLIP. Calling line identification presentation.

CLIR. Calling line identification restriction.

CLK. Clock (module).

CLKRD. Clock redrive (module).

clock module (CLK). A module of the 2220 Model 300 or 500 that transmits clock signals to the line interface couplers (LICs). It is optional and can have a backup.

clock redrive (CLKRD). A module of the 2220 Model 501 that drives the signals from the Model 500 clock module to the adapters of the Model 501. The clock redrive is optional and can have a backup.

clock references. In an Nways Switch, the software function that controls the transmission of clock signals to the LICs where they are used for bit synchronization.

CLP. Cell loss priority.

CMIP. Common management information protocol.

CMIS. Common management information services.

CMOT. CMIP over TCP/IP.

CNM. Communication network management.

code file. A named set of records stored as a unit in a change control server. An Nways Switch code file can include data or internal code.

COLP. Connected line identification presentation.

COLR. Connected line identification restriction.

configuration station. See Nways Switch configuration station.

control point (CP). In an Nways Switch, a logical resource that provides network control functions. It can have a backup.

CP. Control point.

CPA. Control point adapter (module).

CPE. Customer premises equipment.

CP spanning tree. In a 2220 network, a distribution tree that connects the Nways Switch control points through trunk lines. The CP spanning tree supplies a very fast and efficient way to multicast control messages such as network topology data.

CRC. Cyclic redundancy check.

CSU. Channel access unit.

CTD. Cell transfer delay.

data circuit-terminating equipment (DCE). An equipment installed on a user premises that provides all the functions required to establish, maintain, and terminate a connection, and to do the signal conversion

and coding between a data terminal equipment (DTE) and a line. A DCE can be separate piece of equipment or part of other equipment.

data terminal equipment (DTE). That part of a data station that serves as data source, data sink, or both, and provides the data communication control function depending on the type of protocol used.

dB. Decibel.

dBm. Decibel based on 1 milliwatt.

DC48. Dc power input type -48V

dc. Direct current.

DCD. Dc distribution (module).

DCE. Data circuit-terminating equipment.

DDI. Direct dialing-in.

DE. Discard eligibility.

decibel (dB). (1) One tenth of a bel. (2) A unit that expresses the ratio of two power levels on a logarithmic scale. (3) A unit for measuring relative power. The number of decibels is 10 times the logarithm (base 10) of the ratio of the measured power levels; if the measured levels are voltages (across the same or equal resistance), the number of decibels is 20 times the log of the ratio.

decibel based on 1 milliwatt (dBm). A unit of absolute power measurement that is scaled such that 0 dBm equals 1 milliwatt.

dialog box. On the screen of a station, an area with entry fields and push buttons. (Also called dialog.)

DLCI. Data link connection identifier.

DNPT. Destination numbering plan table.

DSP. Digital service processor.

DSU. Data service unit.

DTE. Data terminal equipment.

DTMF. Dual-tone modulation frequency.

DTR. Data terminal ready.

dummy module. In an Nways Switch, a cover inserted in the place of a module to ensure correct air cooling inside a logic subrack. During normal operation, the dummy modules must not be removed.

E1 standard. A European standard for TDM digital transmission service at 2.048 Mbps.

E3 standard. A European standard for TDM digital transmission service at 34.368 Mbps. An E3 line can transport up to 16 E1 circuits.

E&M. Earth & mark.

ECMA. European Computers Manufacturers Association.

EIA. Electronics Industries Association.

equivalent capacity. The minimum amount of bandwidth needed by a connection to ensure that the packet loss ratio is below a specified threshold.

ESF. Extended status flags.

ETS. European telecommunication standard.

FANB. Fan box.

FAT. File allocation table.

fax. Document received from a facsimile machine. Synonym for telecopy.

FCS. Frame check sequence.

FDDI. Fiber Distributed Data Interface.

FE1. Fractional E1.

FECN. Forward explicit congestion notification.

FEP. Front-end processor.

fiber. Synonym for optical fiber.

fiber budget. The optical power loss as result of the number of connections in the optical fiber link subtracted from the working budget. The loss as a result of connections includes connector loss and splice loss. The fiber budget is expressed in decibels.

Fiber Distributed Data Interface (FDDI). A U.S. standard for 100 Mbps token-ring LANs using optical fiber cables over distances of several kilometers.

fiber optic cable. Synonym for optical fiber.

FR. Frame relay.

FRAD. Frame-relay access device.

frame relay (FR). A connection-oriented protocol to transport data frames over a fast packet-network with guaranteed end-to-end quality of service.

FRFH. Frame-relay frame handler.

front-end processor (FEP). A processor, such as the IBM 3745, 3746 Model 900 or 950, or 3174, that relieves a main frame from communication control tasks.

FRTE. Frame-relay terminal equipment.

FRU. Field replaceable unit.

FT1. Fractional T1.

FTP. File transfer protocol.

Gbps. Gigabit per second (10 to the power of 9 bits per second).

GCRA. Generic cell rate algorithm.

GFP. Generic function protocol.

GFT. Generic function transport.

GSM. Group special mobile.

GUI. Graphical user interface.

HDB3. High-density bipolar 3.

HDLC. High-level data link control.

high-level data link control (HDLC). A data network protocol.

hot pluggable. Refers to a hardware component that can be installed or removed without disturbing the operation of any other resource that is not connected to, or dependent, on this component.

HPFS. High-performance file system.

HPRI. High priority.

HSAn. High-speed adapter type n (module).

HSDS. High-speed digital services.

HSSI. High-speed serial interface.

hub (intelligent). A wiring concentrator, such as the IBM 8260, that supplies bridging and routing functions for LANs with different cables and protocols.

hunt group. See X.25 hunt group.

IDNX. Integrated Digital Network Exchange.

IE. Information element.

ILMI. Interim local management interface.

IMU. Inverse multiplexing unit

Integrated Digital Network Exchange (IDNX). A processor integrating voice, data, and image applications. It also manages transmission resources and connects to multiplexers and network management support systems. It permits integration of equipment from different vendors.

integrated services digital network (ISDN). A digital end-to-end public or private network that supports multiple services including, but not limited to, voice and data.

IP. Internet Protocol.

IP gateway adapter. In an Nways Switch, a port adapter that routes the IP control between the NAS and the network management station.

ISDN. Integrated services digital network.

ISDN network interface. A logical resource generated by the Nways Switch Control Program to provide access services to a physical ISDN or QSIG port line. An ISDN network interface sets up and maintains connections between calling ISDN terminal equipments and called terminal equipments attached through other Nways Switches.

ISO. International Organization for Standardization.

isochronous. Refers to transmission at a constant bit rate where there is a clock relationship between source and destination. The bit rates are the same on the destination and source.

ITU-T. International Telecommunication Union - Telecommunication (replaces CCITT).

jitter. Undesirable variations in the transmission delay of a digital signal. Also called cell delay variation (CDV).

KB. Kilobyte (storage capacity, 1024 bytes).

kbps. Kilobit per second (1000 bits per second).

LAN. Local area network.

LAPB. Link access procedure for B-channel.

LAPD. Link access procedure for D-channel.

LCB. Line connection box.

LCBB. Line connection box, base (LCEB and LCPB).

LCBE. Line connection box, expansion (LCEE and LCPE).

LCEB. Line connection enclosure, base.

LCEE. Line connection enclosure, expansion.

LCPB. Line connection power, base.

LCPE. Line connection power, expansion.

LCR. Least cost routing.

LED. Light-emitting diode.

LICn. Line interface coupler type n (module).

line. In a 2220 network, any physical medium, such as a telephone wire, microwave beam, or optical fiber, that transmits information. A line can be a trunk line or a port line.

line connection box (LCB). A metallic box that:

- Multiplexes up to 15 low-speed lines. There can be up to four LCBs per LIC type 511 for a total of 60 lines (two LCBs and 30 lines per LIC connector).
- Reduces cable lengths between Nways Switch and DCE or DTE locations.

An LCB fits in a standard 19-inch rack. Each one houses up to 15 active remote connectors (ARCs).

line interface coupler (LIC). In an Nways Switch, a module that physically attaches trunk or port lines. Each line interface coupler is associated with a trunk or port adapter, and supports specific line interfaces.

LIV. Link integrity verification.

LMI. Local management interface.

local area network (LAN). A computer network located on a user premises in a limited geographical area.

logical port. (Also called NBBS port.) A logical resource generated by the Nways Switch Control Program to provide access services to a physical port line (or channel of a TDM port line) using HDLC, FR, or CES protocol. A logical port sets up and maintains its predefined connections.

logical trunk. (Also called NBBS trunk.) A logical resource generated by the Nways Switch Control Program to provide transport services to a physical trunk line (or channel of a TDM trunk line). A logical trunk is mainly responsible for optimizing bandwidth and maintaining the CP spanning tree.

LSAn. Low-speed adapter type n (module).

MA/SR. Multi-access/sub-rate.

management access. Refers to an Nways Switch that connects a network management station or a change control server to a 2220 network through its service bus, which is a dedicated Ethernet LAN.

MB. Megabyte (storage capacity, 1 048 576 bytes).

Mbps. Megabit per second (10 to the power of 6 bits per second).

MBS. Maximum burst size.

MLT. Multiple logical trunks.

module. In an Nways Switch, a hardware unit plugged in a slot of the logic subrack. It houses, for example, an

adapter, a line interface coupler, or a voice server extension. All modules are hot pluggable.

ms. Millisecond (1/1000 second).

NAS. Nways Switch administration station.

NBBS. Networking BroadBand Services (architecture).

NBBS architecture. See Networking BroadBand Services.

NBBS connection. See potential connection and virtual connection.

NBBS network. A network built with IBM 2220 Nways BroadBand Switches and conforming to the IBM Networking BroadBand Services (NBBS) architecture.

NBBS port. See logical port.

NBBS trunk. See logical trunk.

NCT2. Nways Switch Configuration Tool Version 2.

NDPS. Non-disruptive path switching.

NEM. Nways Enterprise Manager (see 2220 Nways Switch Manager).

network control. Functions that are performed by an Nways Switch control point to:

- Allocate and control the Nways Switch resources
- Provide topology and directory services
- Select routes
- Control congestion.

network management station (NMS). A station that runs IBM NetView for AIX and the 2220 Nways Switch Manager. It is used to manage network topology, accounting, performance, configuration, and error reporting.

network node interface (NNI). An interface between nodes in a communication network.

Network Support Center (NSC). A location from which IBM remotely supports 2220 networks.

Networking BroadBand Services (NBBS). An IBM architecture for high-speed networking that complements ATM standards and provides access services, transport services, and network control to user traffic.

NIC. Network Information Center.

NMS. Network management station.

NNI. Network node interface.

NPT. Numbering plan table.

NR. Non-reserved.

NRT. Non-real-time.

NRZI. Non-return-to-zero inverted recording.

NRZ-1. Non-return-to-zero change-on-ones recording.

NSAP. Network service address point.

NSC. Network Support Center.

NSM. (See 2220 Nways Switch Manager)

NVDM. NetView Distribution Manager for AIX.

NTT. Nippon Telegraph & Telephone (Corporation).

numbering plan table (NPT). A set of parameters, organized in origin NPT and destination NPT, that defines a type of called ISDN numbers. A numbering plan table is associated with each ISDN network interface.

Nways 2220 Switch Manager (2220 Switch Manager). An IBM licensed program that runs under NetView for AIX to manage the 2220 Nways Switch operation and configuration from a network management station. It replaces the Nways Enterprise Manager (NEM) which is no longer available.

Nways BroadBand Switch. Synonym for 2220 Nways BroadBand Switch.

Nways Enterprise Manager (NEM). An IBM licensed program that was used under NetView for AIX in a network management station to manage Nways Switches, routers, and bridges in a 2220 network (see 2220 Nways Switch Manager).

Nways Switch. Synonym for 2220 Nways BroadBand Switch.

Nways Switch administration station (NAS). A station attached to each 2220 to run the Control Program, and control and service the Nways Switch locally.

Nways Switch configuration station. A mandatory OS/2 or AIX station that runs a stand-alone version of the Nways Switch Configuration Tool Version 2 (NCT2) and stores the centralized configuration database of the NBBS network. An OS/2 station can be used as a remote user console.

Nways Switch Configuration Tool Version 2 (NCT2). A component of the Nways Switch Control Program that is used to configure physical and logical resources. It is also used in stand-alone version under OS/2 or AIX .

Nways Switch Control Program. The IBM licensed program that runs in the NAS and adapters of the 2220 Nways Switch. It includes a CMIP agent to work with the 2220 Switch Manager.

Nways 2220 Switch Manager for AIX. (See Nways 2220 Switch Manager)

Nways Switch Resource Control. A component of the Nways Switch Control Program. It is used from the NAS of an Nways Switch or from a remote user console to control resources and configuration files.

OAM. Operation, administration, and maintenance.

OC3. Optical carrier level 3.

ONPT. Origin numbering plan table.

operation, administration, and maintenance (OAM). A group of functions coded in specific ATM cells to handle alarms and loopback tests on ATM connections.

optical fiber. In fiber optics technology, a wave guide that propagates optical signals from light-generating transmitters to light-detecting receivers.

OSI. Open systems interconnection.

packet loss ratio. The probability that a packet will not reach its destination or not reach it in a specified time. It is obtained by dividing the number of packets lost in transmission by the total number transmitted.

packet transfer mode (PTM). The native transfer mode of the NBBS architecture. PTM divides the traffic into packets of variable length.

PBX. Private branch exchange.

PCM. Pulse code modulation.

PCR. Peak cell rate.

PDH. Plesiochronous digital hierarchy.

permanent virtual circuit (PVC). A virtual circuit that has a logical channel permanently assigned to it at each item of data terminal equipment. It is activated by a program or by a network operator request.

plesiochronous. Refers to transmission at a nominal bit rate where the source and destination are controlled by different clocks. The bit rates are nearly the same.

PLP. Packet layer protocol.

PNP. Private numbering plan.

port. See logical port.

port adapter. In an Nways Switch, a module that provides access services to one or more port lines. Each port adapter is associated with a line interface coupler (LIC).

port line. A communication line that connects a device on user premises to an Nways Switch and serves as a port to the 2220 network. Port lines have different protocols and interfaces.

position. When configuring an Nways Switch, the position parameter indicates the line attachment number on the LIC module (1 to 8, depending on the LIC type).

potential connection. A predefined connection through a 2220 network between two HDLC, CES, or frame-relay devices.

PPP. Point-to-point protocol.

PRA. Primary Rate Access.

private branch exchange (PBX). A switching system located on a user premises that relays inside lines (extensions) and provides access to the public telephone network.

PRS. Primary reference source.

PSDN. Packet switched data network.

PSN. Public switched network.

PSTN. Public switched telephone network.

PTF. Program temporary fix.

PTM. Packet transfer mode.

PTNX. Private telecommunications network exchange.

pulse code modulation (PCM). A standard adopted for the digitalization of analog voice signals. In PCM, voice is sampled at a rate of 8 kHz and each sample is coded in an 8-bit frame.

PVC. Permanent virtual circuit.

Q signaling (QSIG). An international standard for signaling procedures in private telecommunication networks. It applies to the PBX-to-Nways Switch interface, which is called the Q reference point.

QoS. Quality of service.

QSIG. Q signaling.

quality of service (QoS). In a 2220 network, a set of parameters that guarantees the characteristics of a connection, mainly its end-to-end delay, delay variation, and packet loss tolerance.

RABM. Router and Bridge Manager.

rack. A metallic structure, with a standard 19-inch width, that houses the hardware elements of an Nways Switch, that is, logic subrack with modules, fan boxes, and power units. When configuring an Nways Switch, the rack parameter indicates the 2220 Model (rack A is the Model 300 or 500, and rack B is the Model 501).

RDI. Remote defect indication.

real-time processing. Refers to the manipulations of data that are required, or generated, by certain process

while the process is in operation. Usually, the results influence the process and, perhaps, related processes.

remote user console. A station running OS/2, TCP/IP, and Nways Switch Resource Control. It can be connected to the NAS of an Nways Switch to remotely control and service it.

resource. In an Nways Switch, a hardware element or a logical entity created by the Control Program. Adapters, modules, and line attachments are examples of physical resources. Control points, logical trunks, logical ports, and network interfaces are examples of logical resources.

resource profile. A record of the characteristics of an Nways Switch resource. It includes (for example) the part number or module name, the change level, and the name and phone number of the person to contact when a problem occurs.

RETAIN. Remote Technical Assistance Information Network

RIP. Route Information Protocol.

router. An attaching device that connects two LAN segments of the same or different architectures. It can also be connected to a wide area network. A router works at the network level (layer 3) of the OSI reference model by determining the best paths for network traffic flows.

Router And Bridge Manager. An application that provides distributed management for routers such as the IBM 2210 or 2216, bridges such as the IBM 8229, and communication controllers such as the IBM 3746 in IP mode.

RS. Recommended specification.

RSF. Remote support facility.

RSN. Receive sequence number.

RT. Real-time.

RVX. RS/EIA-232, V.24/V.35, X.21.

s. Second.

SCR. Sustainable cell rate.

SDH. Synchronous digital hierarchy.

SDLC. Synchronous data link control.

SDT. Structured data transfer.

serial line internet protocol (SLIP). A TCP/IP protocol used on a point-to-point connection between two IP hosts over a serial line (for example, an RS/EIA-232 connection to a modem over a telephone line).

SLA. Serial link architecture.

SLIP. Serial line internet protocol.

slot. When configuring an Nways Switch, the slot parameter indicates the module location (1 to 12) in the logic subrack.

SNA. Systems Network Architecture.

SNMP. Simple Network Management Protocol.

SONET. Synchronous optical network.

spanning tree. See CP spanning tree.

SRC. System reference code.

SSN. Send sequence number.

station. A microcomputer that is connected to a host or a network and at which a user can run applications.

STM-1. Synchronous transport module type 1.

STS-3c. Synchronous transport signal type 3 concatenated.

SUB. Subaddress.

subrack. A metallic structure installed in an Nways Switch rack. A logic subrack holds modules. A power subrack holds power supply components.

SVC. Switched virtual circuit.

SW. Switch (module).

switch module (SW). A module of the 2220 Model 300 or 500 that interconnects the adapters through an ATM cell switch. It can have a backup.

switch redrive (SWRD). A module of the 2220 Model 501 that drives the signals from the switch module in the Model 500 to the adapters of the Model 501. It can have a backup.

SWRD. switch redrive (module)

switched virtual circuit (SVC). A connection set up from a calling address to a called address following a call establishment protocol. It is released when a clear request signal is received.

synchronous digital hierarchy (SDH). A international recommendation for the internal operation of carrier optical networks.

synchronous optical network (SONET). A U.S. standard for transmitting digital information over optical interfaces. It is closely related to the international recommendation for synchronous digital hierarchy (SDH).

T1 standard. A TDM digital transmission service with a basic rate of 1.544 Mbps. Also called DS-1.

T3 standard. A TDM digital transmission service with a basic rate of 44.736 Mbps. A T3 line can transport up to 28 T1 circuits. Also called DS-3.

TCPA. Trunk and control point adapter.

TCP/IP. Transmission Control Protocol/ Internet Protocol.

TDM. Time division multiplexing.

TE. Terminal equipment.

Telnet. In TCP/IP, an application protocol that allows a user at one site to access a remote system as if the display station were locally attached. Telnet uses the Transmission Control Protocol (TCP) as the underlying protocol.

time division multiplexing (TDM). The process of breaking the bandwidth on a communication line into a number of channels, possibly of different size.

TME. Tivoli Management Environment.

TMN. Telecommunication Management Network.

TPA. Trunk or port adapter.

Transmission Control Protocol/ Internet Protocol (TCP/IP). A set of communication protocols that support peer-to-peer connections over both local and wide area networks.

transport services. Functions that are performed by a trunk adapter of an Nways Switch to:

- Support the attachment of trunk lines
- Maximize bandwidth utilization
- Guarantee the quality of service of a connection
- Transfer packets between Nways Switches
- Manage logical queues and schedule transmission.

trunk. See logical trunk.

trunk adapter. In an Nways Switch, a module that provides transport services to one or more trunk lines. Each trunk adapter is associated with a line interface coupler (LIC).

trunk line. In a 2220 network, a high-speed line connecting two Nways Switches. It can be, for example, a copper cable, optical fiber, or radio wave guide and can be leased from telecommunication companies.

UBR. Unspecified bit rate. A best effort service with no quality commitment.

UNI. User network interface.

UPC. Usage parameter control.

URL. Uniform resource locator.

user network interface (UNI). A standardized interface between a user and a communication network.

UTC. Universal time, coordinated.

UUS. User-user signaling.

VBR. Variable bit rate.

VC. Virtual channel.

VCC. Virtual channel connection.

VCI. Virtual channel identifier.

VCN. Virtual circuit number.

virtual channel (VC). In ATM, a unidirectional route between two ATM devices. Virtual channels always come in pairs, one in each direction. They follow virtual paths.

virtual channel connection (VCC). In ATM, a unidirectional connection established over a virtual channel. Virtual channel connections always come in pairs, one VCC in each direction.

virtual channel identifier (VCI). In ATM, the unique numeric tag that identifies every channel. It is defined by a 16-bit field in the ATM cell header.

virtual connection. In frame relay, the return path of an FR potential connection.

virtual path (VP). In ATM, a group of virtual channels that are switched together as one unit. (Also called VC service.)

virtual path connection (VPC). In ATM, a connection established over a virtual path. Virtual path connections always come in pairs, one VPC in each direction. (Also called VP service.)

virtual path identifier (VPI). In ATM, an 8-bit field in the ATM cell header that indicates the virtual path over which the cell is to be routed.

voice server adapter (VSA). In an Nways Switch, a module that supplies additional voice functions to voice connections operating in pulse code modulation at 64 kbps. It can attach a voice server extension (VSE).

voice server extension (VSE). In an Nways Switch, a module associated with a voice server adapter (VSA) to supply voice functions to an extended number of PCM voice connections.

VP. Virtual path.

VPC. Virtual path connection.

VPD. Vital product data.

VPI. Virtual path identifier.

VPN. Virtual private network.

VSA. Voice server adapter (module).

VSEn. Voice server extension type n (module).

WAN. Wide area network.

wide area network (WAN). A network that provides communication services to a large geographic area. It can use or provide public communication facilities.

window. On the screen of a station, an area with a title bar, a menu bar, and scroll bars.

X.25 hunt group. A group of X.25 network interfaces associated with one common subscriber address. If an interface is busy, the connection searches (hunts) for the other interfaces of the group until a free one is found.

X.25 network interface. A logical resource generated by the Nways Switch Control Program to provide access services to a physical X.25 port line. An X.25 network interface sets up and maintains connections between calling X.25 subscribers and called subscribers attached to other Nways Switches.

X.25 Recommendation. An international standard for the interface between data terminal equipments and packet-switched networks.

X.25 subscriber. An X.25 end-user connected to an X.25 network interface through a DTE. A subscriber is defined by an address and a logical name.

Index

A

access services, frame relay 1
activating a connection 17
adaptation limits 9
ADJ, QoS option 10
AR, traffic option 9
asynchronous status message, LMI 35

B

bandwidth, allocating 21
bandwidth adaptation, details 19
bandwidth adaptation, QoS option 10
bandwidth adaptation with limits 25
bandwidth adaptation without limits 24
bandwidth keeping, QoS option 10
bandwidth management 21
bandwidth mode, selection 31
bandwidth modes 2, 22
bandwidth preemption, details 20
Bc, traffic option 9
burst committed 9
burst in excess 9

C

channel configuration 3
CIR, traffic option 9
CIR defined, bandwidth mode 27
CIR null bandwidth mode 29
committed information rate 9
configuration programs 7
configuring resources 7
congestion management 38
connection, definition 4
connection parameters 8

D

default QoS options 17
DLCI ranges 19

F

fixed bandwidth mode 23
FR connections, configuring 8
FR port, configuring 7
FR port, definition 4
frame format, details 17
frame handling functions 2
Frame Relay over ISDN
 connection parameters 14
 connections 13
 described 4
 port parameters 13
 potential connections 14
 virtual connections 15

frame-relay port, configuring 7
full status message, LMI 34

G

global adapter congestion 39
green traffic 22

H

high priority, QoS option 11
HPRI, details 20
HPRI, QoS option 11

I

information elements, LMI 33

K

KEEP, QoS option 10

L

leaky bucket algorithm 22
line attachments 3
link integrity verification 36
LIV status message, LMI 34
LMI, asynchronous support 37
LMI, bidirectional support 38
LMI, definition 36
LMI, details 32
LMI functions 2
LMI procedures 36
local management interface, details 32
local management interface functions 2
logical port, configuring 7
logical ports, definition 4
low-speed trunk line, QoS option 10
LS, QoS option 10

M

mean bit rate 9
mean bit rate, m 23
mean burst length 9
mean burst length, b 23

N

NCT2 7
NDPS, details 19
NDPS, QoS option 10
NNI specifications 33
non-disruptive path switching, details 19
non-disruptive path switching, QoS option 10
non-real-time traffic, QoS selection 11

- non-reserved, details 31
- non-reserved, QoS option 11
- non-reserved traffic, QoS selection 13
- NR option 11
- Nways Switch Configuration Tool Version 2 7
- Nways Switch Manager 7

P

- peak bit rate 9
- peak bit rate, R 23
- permanent mode 17
- physical lines 3
- policing connections 38
- policing traffic 22
- port parameters 7
- potential connection, configuring 8
- potential connection, definition 4
- predefined QoSs 11

Q

- QoS options 10
- qualities of service, options 10

R

- real-time traffic, details 30
- real-time traffic, QoS selection 12
- red traffic 22

S

- severe adapter congestion 39
- slow adaptation mode 24
- SNA and IP traffic merge 32
- status enquiry message, LMI 33
- system defaults 17

T

- traffic descriptors, frame relay 9
- traffic descriptors, NBBS 9
- traffic descriptors, summary 22
- traffic parameters, frame relay 9
- traffic parameters, NBBS 9

U

- UNI specifications 33

V

- virtual connection, configuring 8
- virtual connection, definition 4
- voice traffic from FRAD 30

Readers' Comments — We'd Like to Hear from You

2220 Nways BroadBand Switch
Models 300, 500, and 501
Planning Series
Frame Relay Interface Specifications

Publication No. GA33-0374-05

Overall, how satisfied are you with the information in this book?

	Very Satisfied	Satisfied	Neutral	Dissatisfied	Very Dissatisfied
Overall satisfaction	<input type="checkbox"/>	<input type="checkbox"/>	<input type="checkbox"/>	<input type="checkbox"/>	<input type="checkbox"/>

How satisfied are you that the information in this book is:

	Very Satisfied	Satisfied	Neutral	Dissatisfied	Very Dissatisfied
Accurate	<input type="checkbox"/>	<input type="checkbox"/>	<input type="checkbox"/>	<input type="checkbox"/>	<input type="checkbox"/>
Complete	<input type="checkbox"/>	<input type="checkbox"/>	<input type="checkbox"/>	<input type="checkbox"/>	<input type="checkbox"/>
Easy to find	<input type="checkbox"/>	<input type="checkbox"/>	<input type="checkbox"/>	<input type="checkbox"/>	<input type="checkbox"/>
Easy to understand	<input type="checkbox"/>	<input type="checkbox"/>	<input type="checkbox"/>	<input type="checkbox"/>	<input type="checkbox"/>
Well organized	<input type="checkbox"/>	<input type="checkbox"/>	<input type="checkbox"/>	<input type="checkbox"/>	<input type="checkbox"/>
Applicable to your tasks	<input type="checkbox"/>	<input type="checkbox"/>	<input type="checkbox"/>	<input type="checkbox"/>	<input type="checkbox"/>

Please tell us how we can improve this book:

Thank you for your responses. May we contact you? Yes No

When you send comments to IBM, you grant IBM a nonexclusive right to use or distribute your comments in any way it believes appropriate without incurring any obligation to you.

Name

Address

Company or Organization

Phone No.



Fold and Tape

Please do not staple

Fold and Tape

PLACE
POSTAGE
STAMP
HERE

IBM France
Centre d'Etudes et Recherches
Service 0798, BP 79
06610 La Gaude, France

Fold and Tape

Please do not staple

Fold and Tape



Printed in Denmark by IBM Danmark A/S

GA33-0374-05

